



TDM

TORQUE DIE & MOLD



TDM 88

TORQUE DIE & MOLD

- TDM 88
- TDM 88 INDEX
- TDM 88 Adjustable

Page 0.1.6

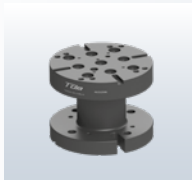

TDM 88

Accessories

- Pins
- Rings
- Bushes
- Rises
- Spacers
- Tombstones

Page 0.1.8



TDM 48

TORQUE DIE & MOLD

- TDM 48
- TDM 48 INDEX

Page 0.1.22



TDM 48

Accessories

- Pins
- Bushes
- Spacer

Page 0.1.26

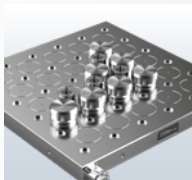

TDM MAG

- Magnetic system for clamping pieces in milling

Page 0.1.30



TDM MAG

- Magnetic plane
- TDM MAG 48

Page 0.1.36



TDM MAG

Accessories

- Pins
- Bush
- Extensions
- Control unit

Page 0.1.38

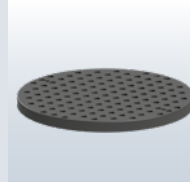

TDM

Accessories

- Plates
- Minipallets
- Spacers
- Adaptor

Page 0.1.42

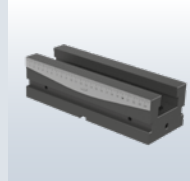

OP 10

Page 0.1.49

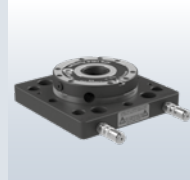

TDM - APS

- APS 140
- Flanges

Page 0.1.53

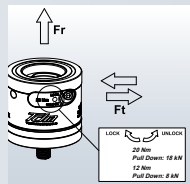

TDM

Technical informations

Page 0.1.59



Benefits

- ▶ Only 3.5 rotation Lock-Unlock
- ▶ High jaws surface contact (Pull down force 18 Kn at 20 Nm)
- ▶ Repeatability <0,005 mm
- ▶ Holding force up to 100 Kn



- ▶ Self centered self compensating jaws



WATCH THE VIDEO



A.T. swinging pin

Benefits

NEW

- Unique pin with twin swinging screw function and floating centering ring of X; Y
Ideal for pieces / molds after hardening



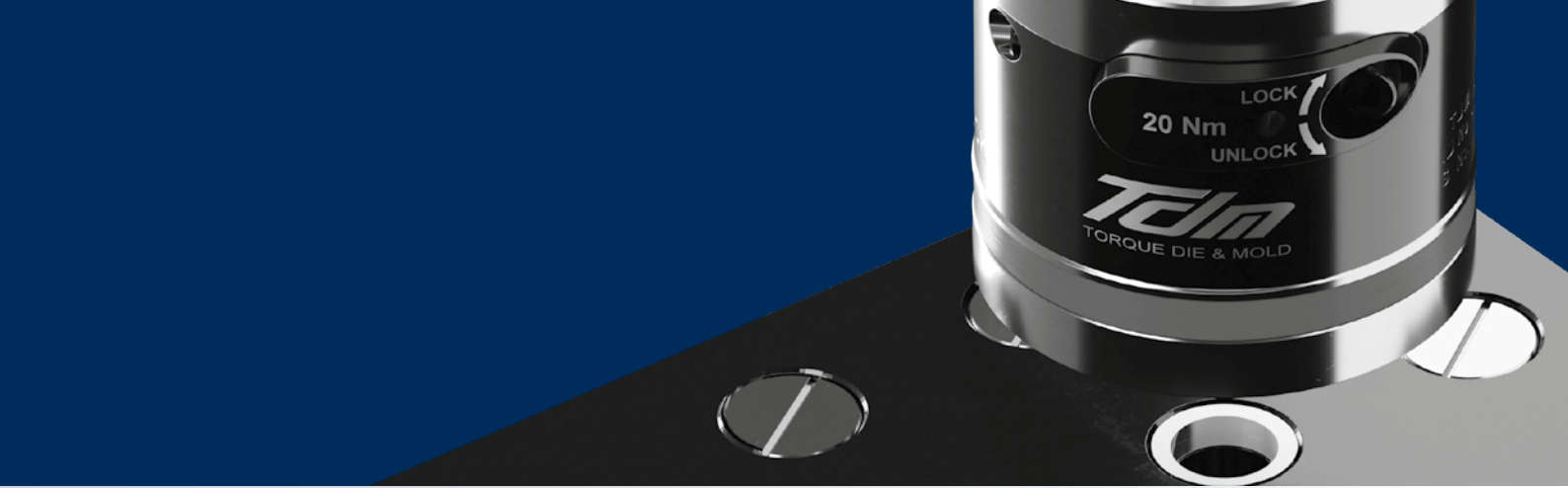

Working examples

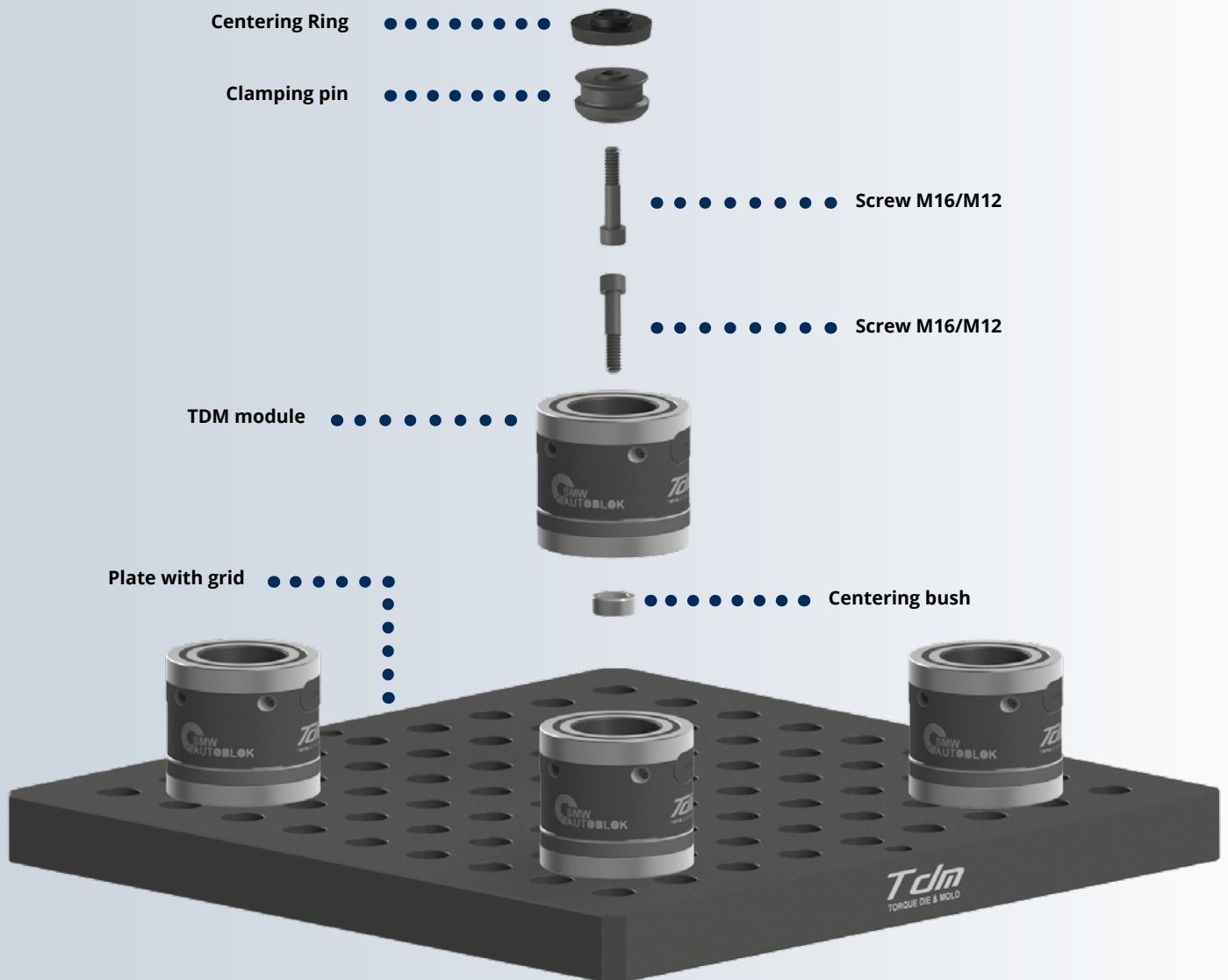

Index Working examples

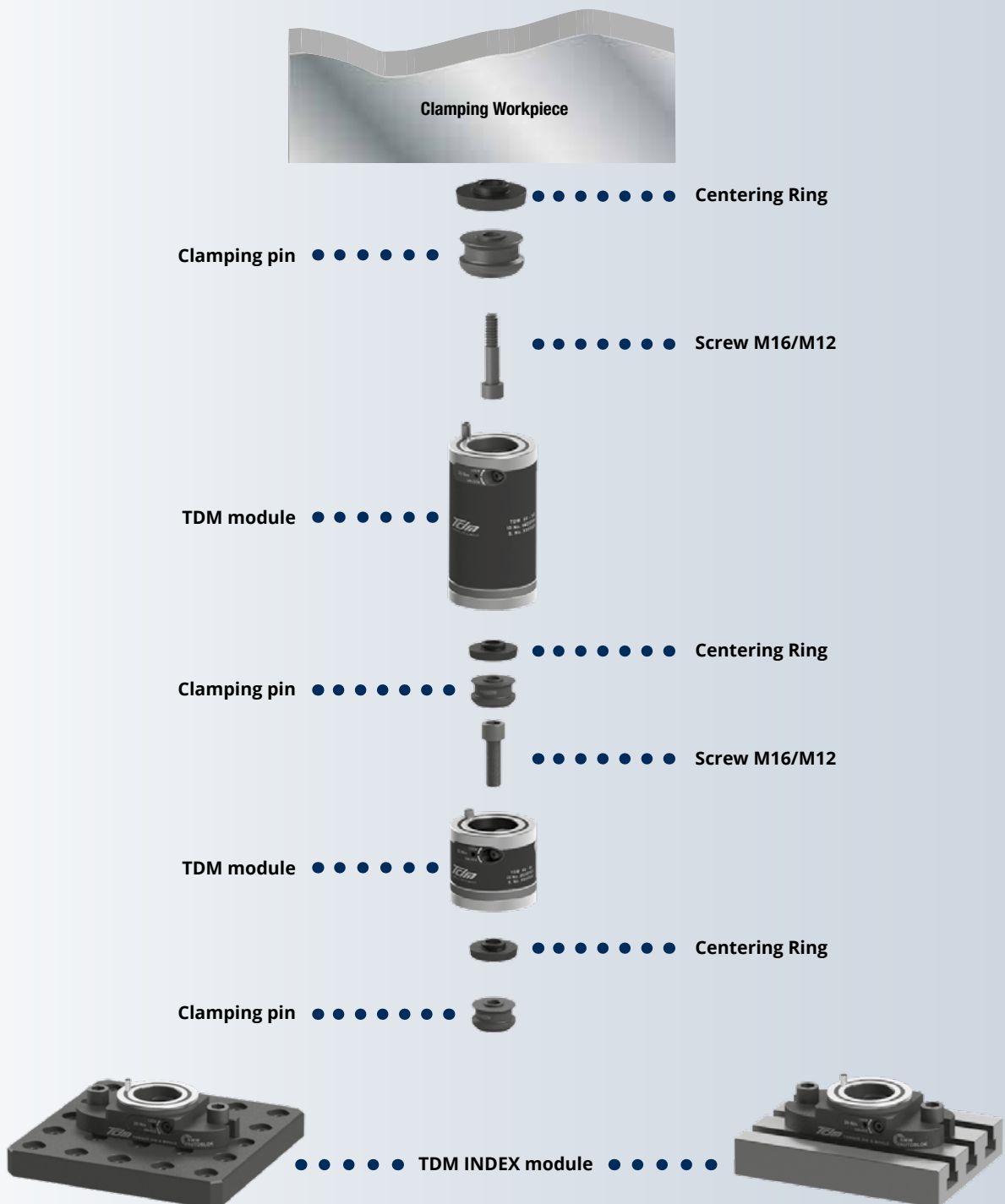



Application/customer benefits

- Huge reduction of set-up times for highest efficiency
- Safe workpiece clamping with maximum holding forces and highest repeatability
- Ideal for mold making and 5-axis machining
- Single quick-actuation for the rapid opening and closing of the modules with only 3.5 rotations
- Flexible configurations for customized use
- Compatible to the proven zero point system APS

Technical features

- Diameter 88mm
- Pull down 18 kN
- Max. torque 20 Nm
- Repeatability < 0.005 mm
- Holding force up to 100Kn
- 2 clamping slides for maximum hold while clamping
- Fully sealed - low maintenance
- Complete with screw 12.9

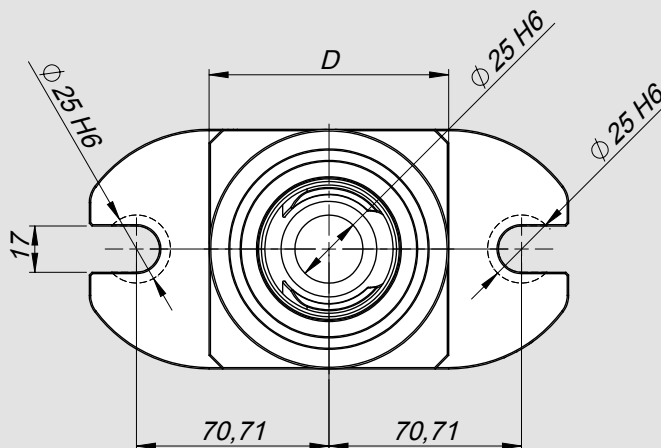
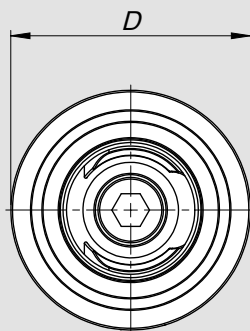
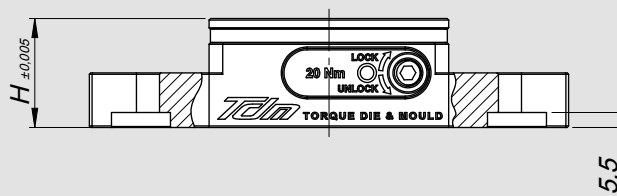
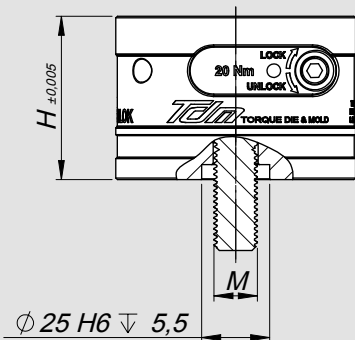

Module	Id. No.	D	H	M*
TDM88 H40	46230101	88	40	-
TDM88 H60	46230102	88	60	M16 **
TDM88 H80	46230103	88	80	M16 ***
TDM88 H160	46230104	88	160	M16 ****

* Complete with screw 12.9

** TCEI-BAS M16X40 UNI 9327 DIN 7984 (Thin head cap screw)

*** TCEI M16X50

**** TCEI M16X110



Application/customer benefits

- Huge reduction of set-up times for highest efficiency
- Safe workpiece clamping with maximum holding forces and highest repeatability
- Ideal for mold making and 5-axis machining
- Single quick-actuation for the rapid opening and closing of the modules with only 3.5 rotations
- Flexible configurations for customized use
- Compatible to the proven zero point system APS

Technical features

- Diameter 88mm
- Pull down force 18 kN
- Max. torque 20 Nm
- Repeatability < 0.005 mm
- Holding force up to 100Kn
- 2 clamping slides for maximum hold while clamping
- Fully sealed - low maintenance
- Complete with screw 12.9

Working example

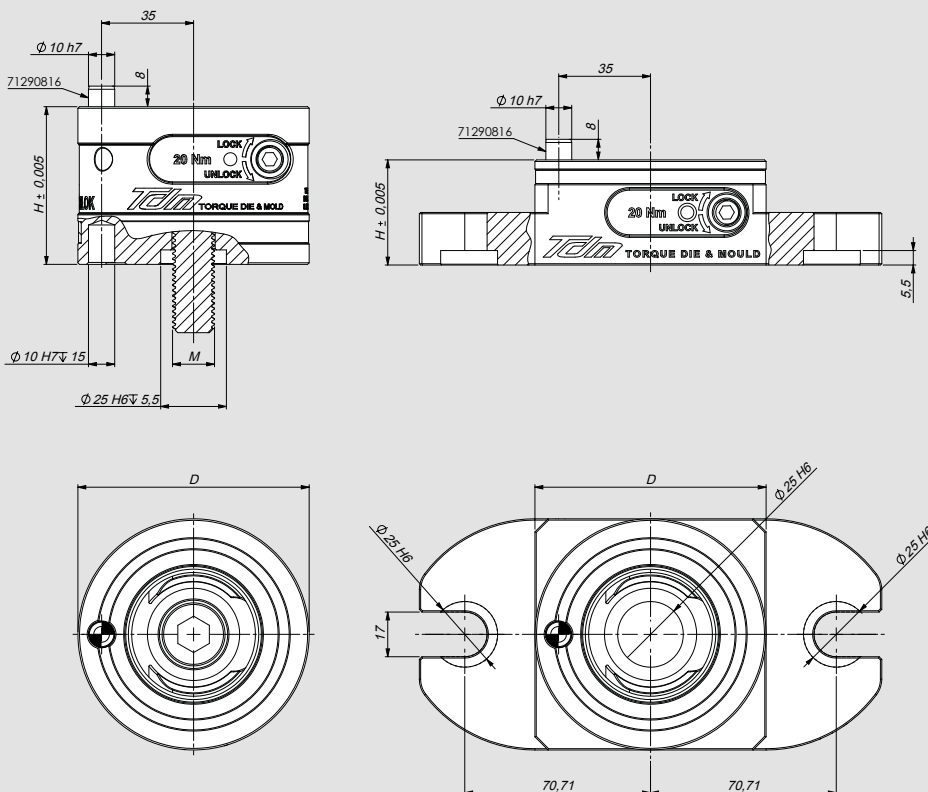

Index Module	Id. No.	D	H	M*
TDM88 Index H40	46230111	88	40	-
TDM88 Index H60	46230112	88	60	M16 **
TDM88 Index H80	46230113	88	80	M16 ***
TDM88 Index H160	46230114	88	160	M16 ****

* Complete with screw 12.9

** TCEI-BAS M16X40 UNI 9327 DIN 7984 (Thin head cap screw)
 *** TCEI M16X50
 **** TCEI M16X110



Often, some pieces may have two or more oblique locating surfaces to each other. Therefore, by fixing one of the surfaces parallel to the machine table through a locking device, the same surfaces which are not parallel to it are oblique.

In these cases, a leveling device must be incorporated between the piece and the machine tool to compensate for the angular misalignment. A normal leveling device compensates for this misalignment by utilizing a spherical coupling.

However, unlike the **TLM**, these leveling devices can have limited stability, are subject to play, and require frequent maintenance.

Therefore, the main function of **TLM** is to be a leveling device for clamping a piece having at least two mutually oblique fixing surfaces in a stable and safe way.

TLM is fully adjustable in height ± 5 mm and can achieve full compensation from 0 degrees up to 20 degrees.

Id. No.

46232050

WATCH THE VIDEO

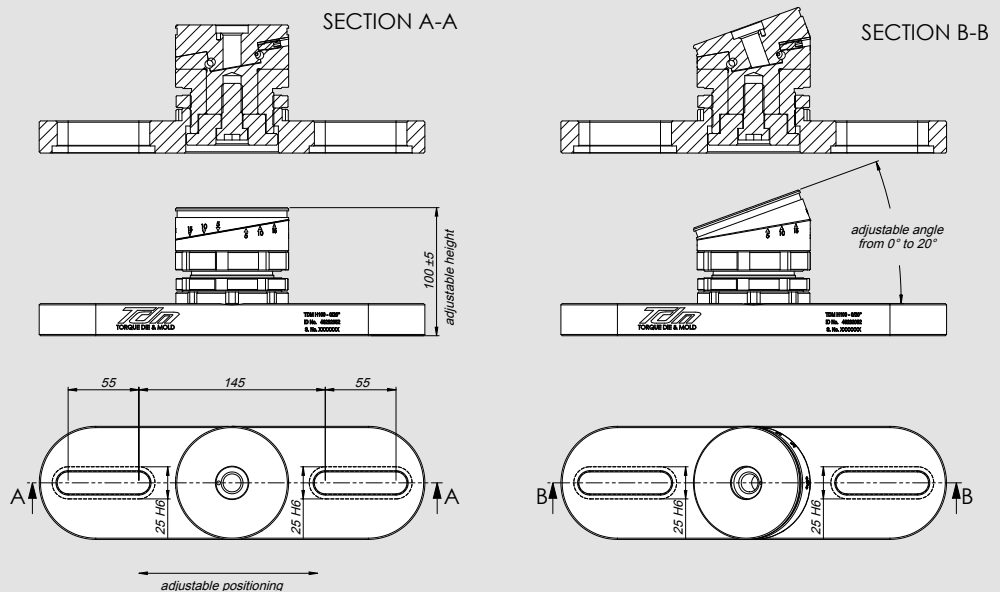

Working example

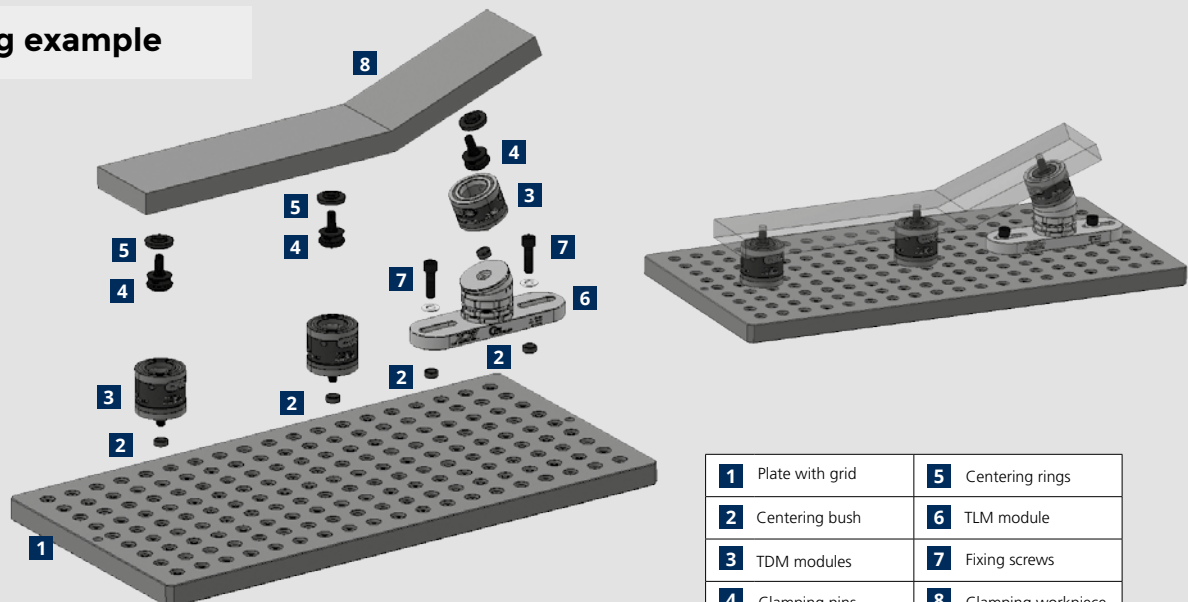

1	Plate with grid	5	Centering rings
2	Centering bush	6	TLM module
3	TDM modules	7	Fixing screws
4	Clamping pins	8	Clamping workpiece

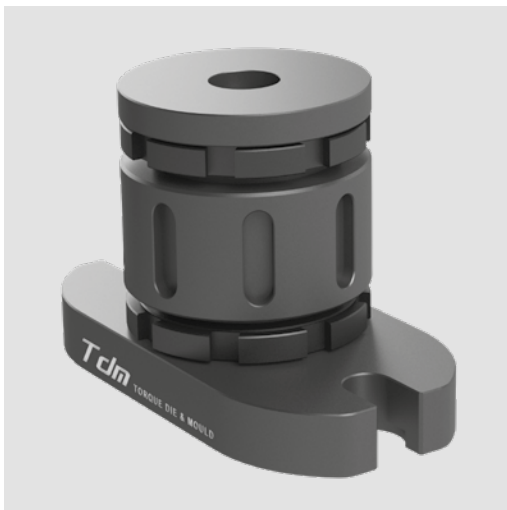

Complete with sector wrench

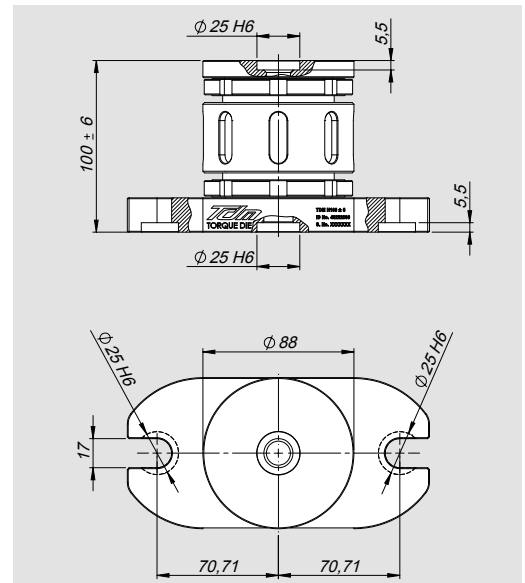

Id. No.

46232000

Working example with module

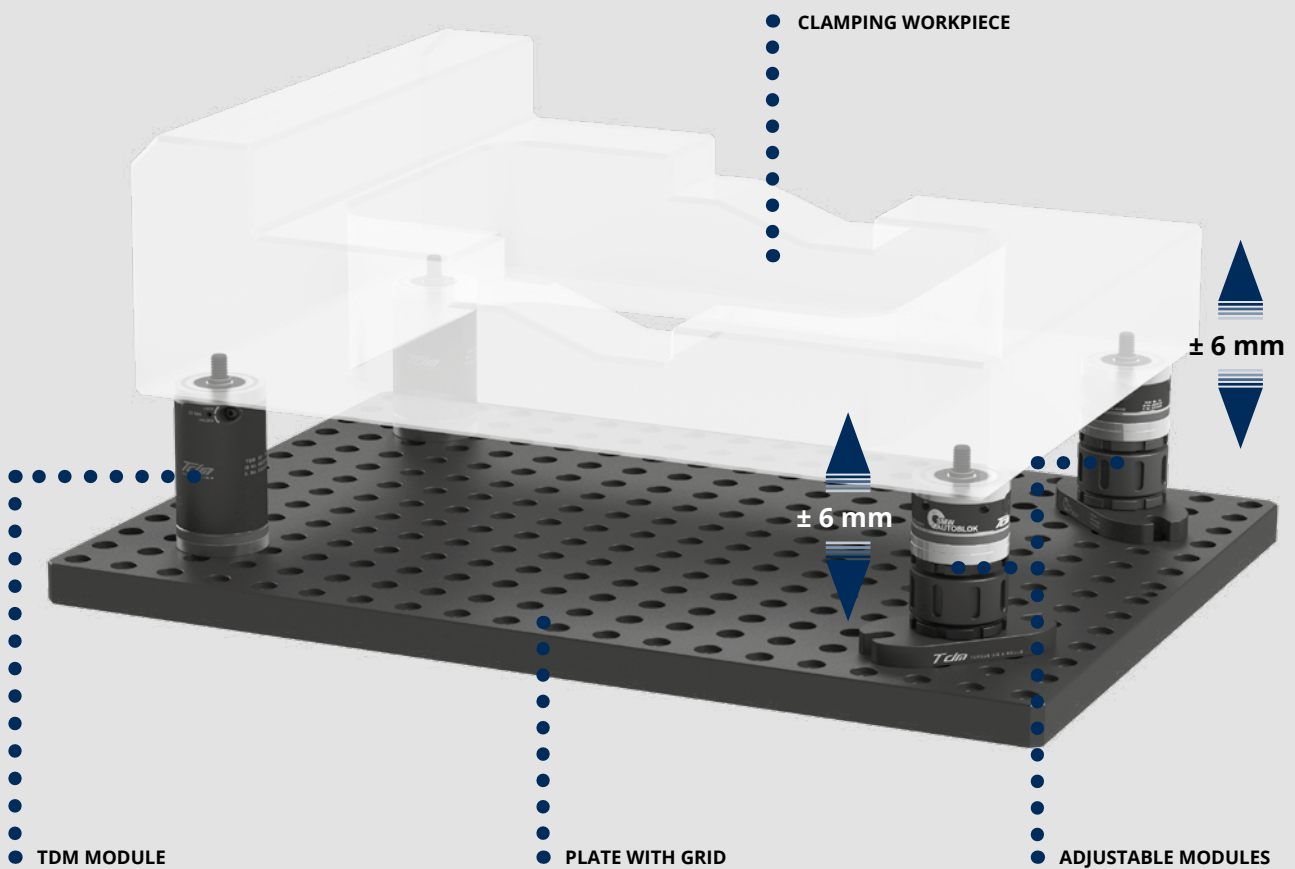



Working examples

Clamping Workpiece (only male)

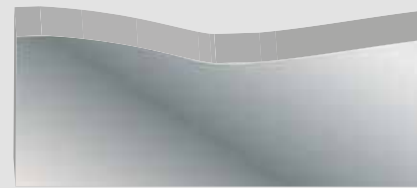

46231114
46231116

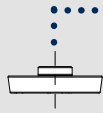

46231118
46231120

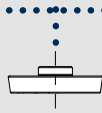

46231322
46231324
46231325

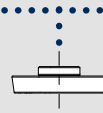

46230210

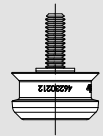

46230212

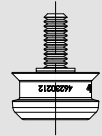

46230216

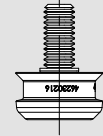

46230104

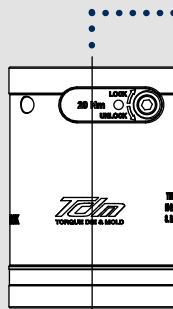

46231125

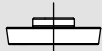

46230316

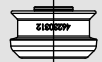

46231125

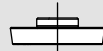

46230316



46230103

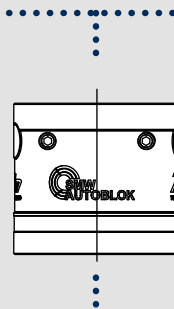

46230102

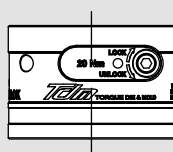

46230103

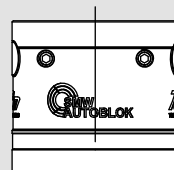

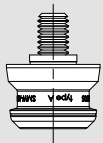
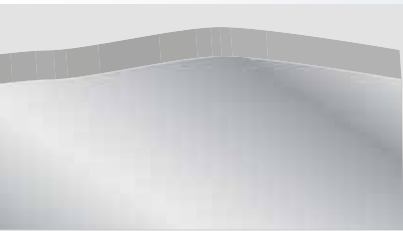

46165705
(APS160)
male

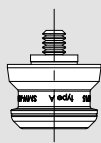

46165715 (APS160)
male (M12)
Female (M16)

46230102

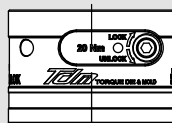

46231125



46230316



46230104

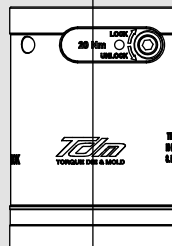

46231125



46230316



46230104

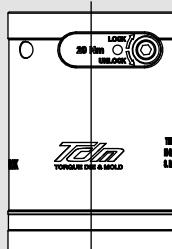

46230101

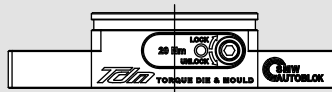

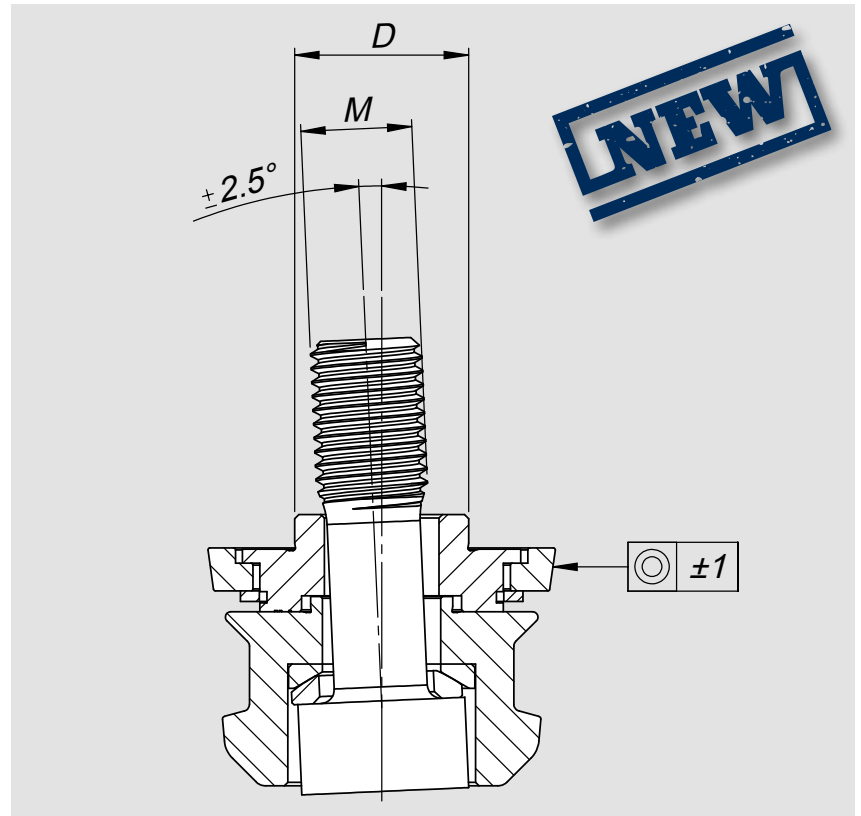

Id. No.	D	M
46231416	16 H6	M10
46231420	20 H6	M12
46231424	24 H6	M16
46231425	25 H6	M16

Working example

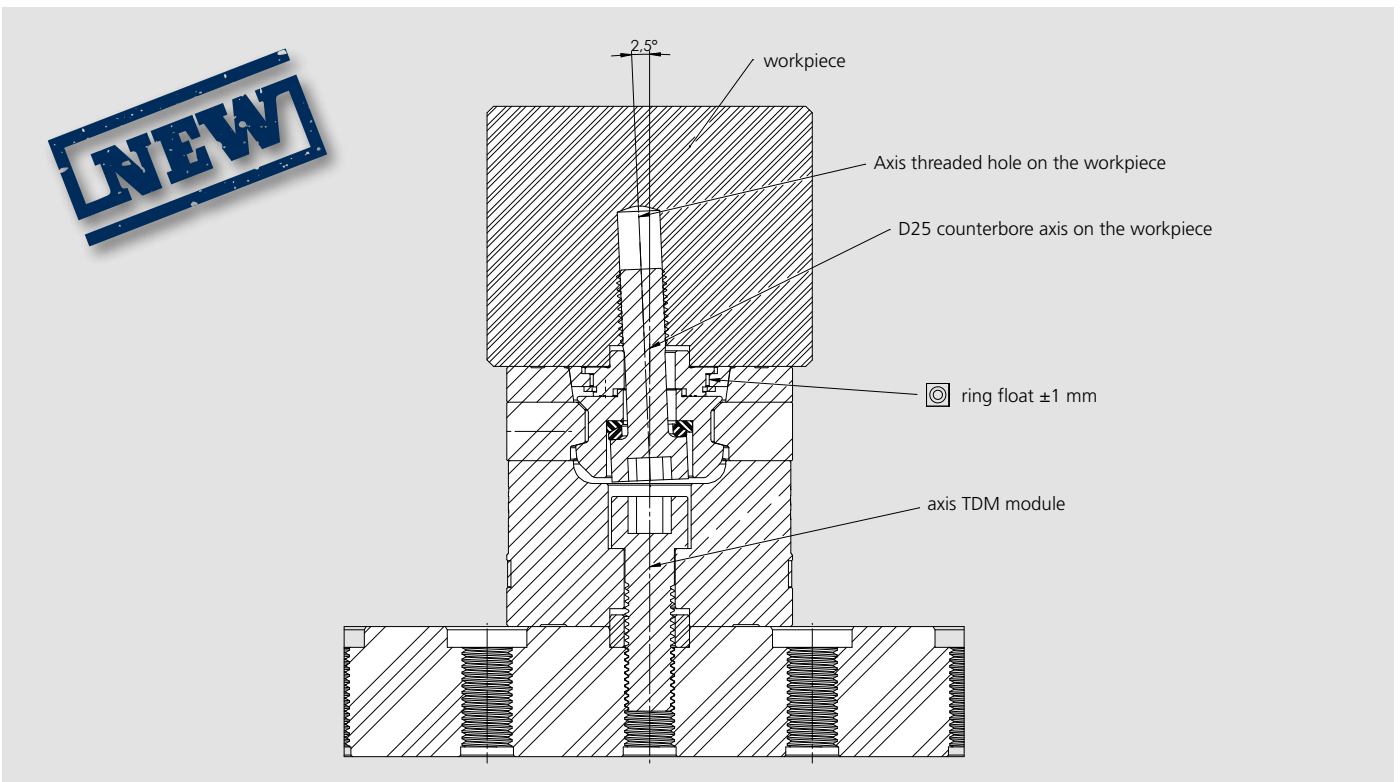

CENTERING RINGS

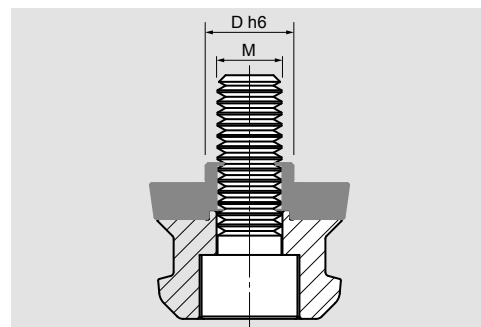
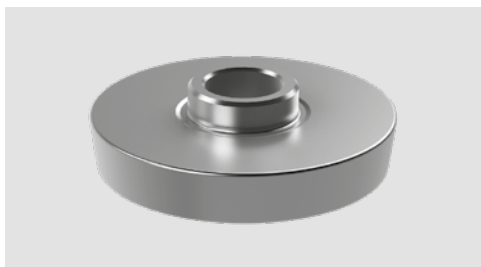

Id. No.	D	M	
46231110	10 h6	M6	A
46231111	11 h6	M6	A
46231112	12 h6	M8	A
46231114	14 h6	M8 / M10	A
46231116	16 h6	M8 / M10	A
46231118	18 h6	M10 / M12	A
46231120	20 h6	M10 / M12	A
46231122	22 h6	M10 / M12 / M16	A
46231124	24 h6	M10 / M12 / M16	A
46231125	25 h6	M10 / M12 / M16	A

Id. No.	D	M	
46231110	10 h6	M6	C
46231111	11 h6	M6	C
46231112	12 h6	M8	C
46231314	14 h6	M10	C
46231316	16 h6	M10	C
46231318	18 h6	M10 / M12	C
46231320	20 h6	M10 / M12	C
46231322	22 h6	M10 / M12 / M16	C
46231324	24 h6	M10 / M12 / M16	C
46231325	25 h6	M10 / M12 / M16	C

REDUCTION BUSH

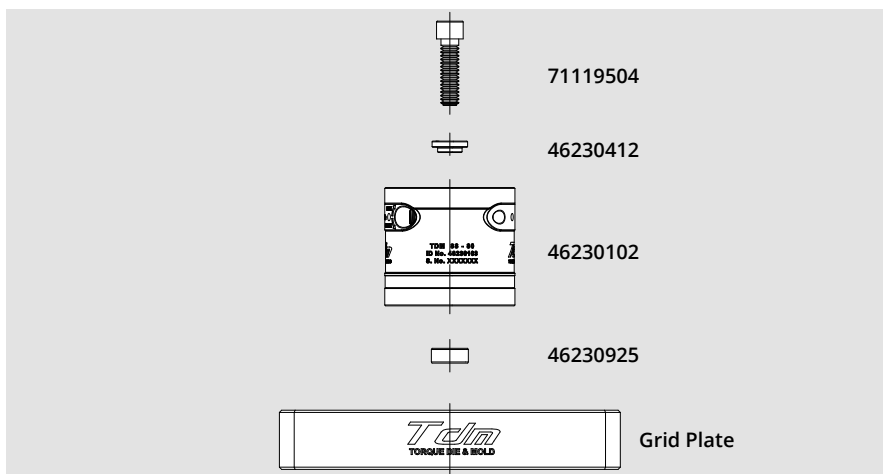
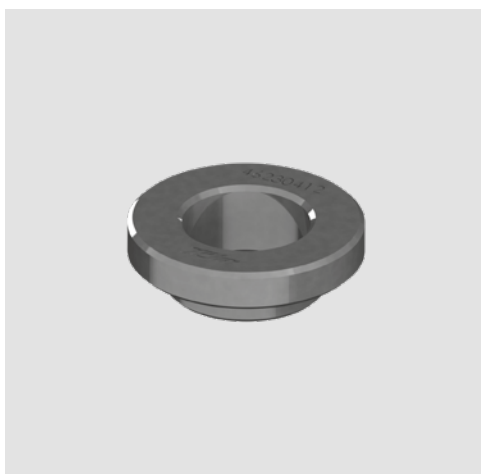

18- Assembling with reduction	M12			M10		
	Id. No. washer	Id. No. screw	screw length	Id. No. washer	Id. No. screw	screw length
TDM H 60 *	46230412	71119504	35	46230410	71119503	35
TDM H 80 *	46230412	71113107	45	46230410	71113087	45
TDM H 160 *	46230412	71119345	105	46230410	71119344	105

CENTERING BUSH

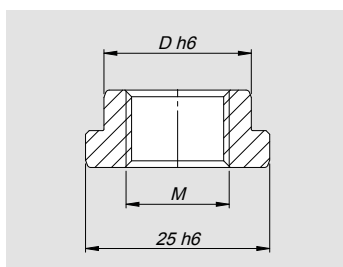
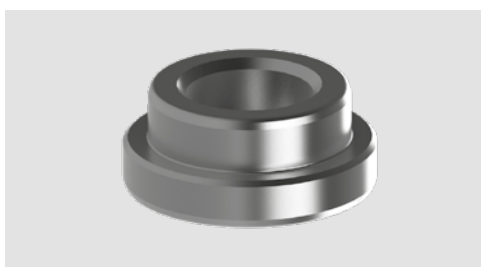

Id. No.	D	Thread for extraction * M
46230918	18	M14 x 1,5
46230920	20	M14 x 1,5
46230922	22	M18 x 1,5
46230924	24	M18 x 1,5
46230925	25	M18 x 1,5

* Extractor page 0.1.44

UNIVERSAL RISER FOR TDM MODULES 48/88 AND IMG 88, IMG 125-220, IMG 160-270 VISE

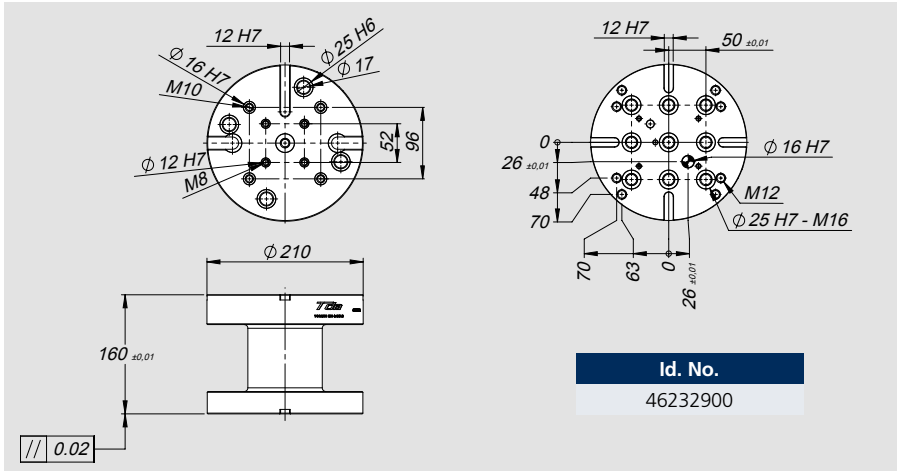

Working examples

RISER WITH GRID

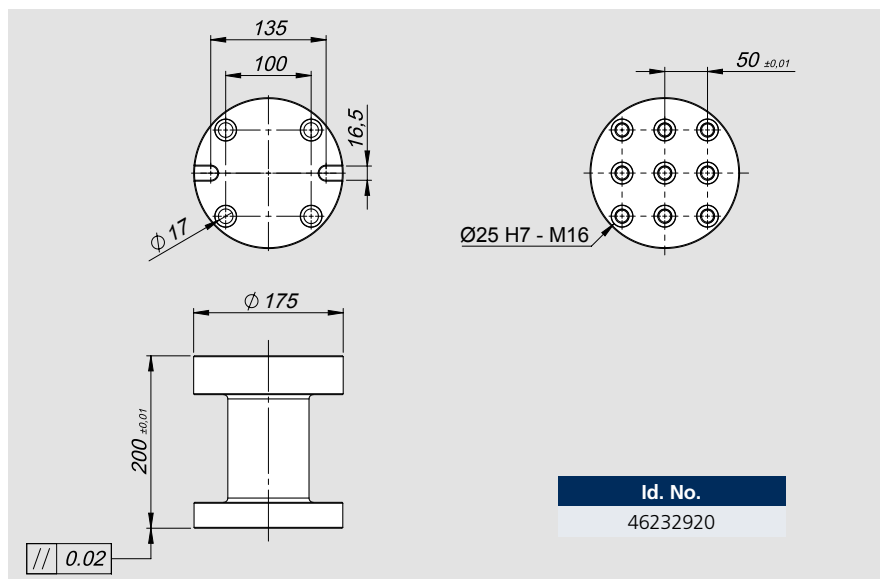

SPACERS

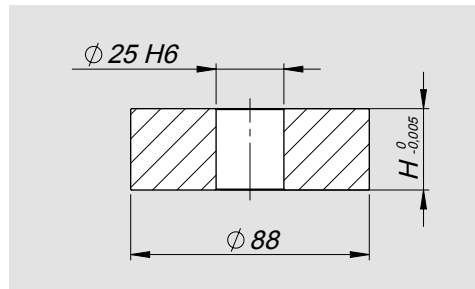
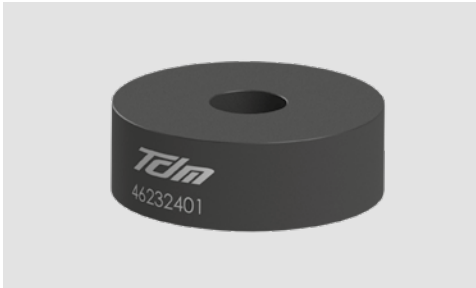

Id. No.	H
46232410	10
46232430	30

MACHINABLE SPACERS

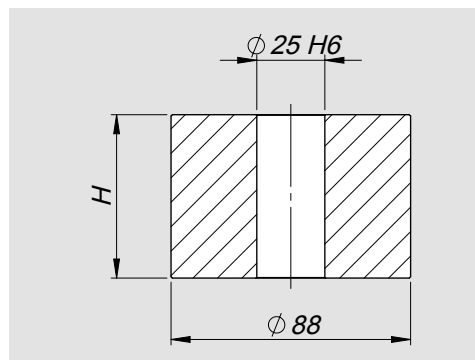

Id. No.	H
46232801	60
46232802	80

Spacer and Adaptor working examples

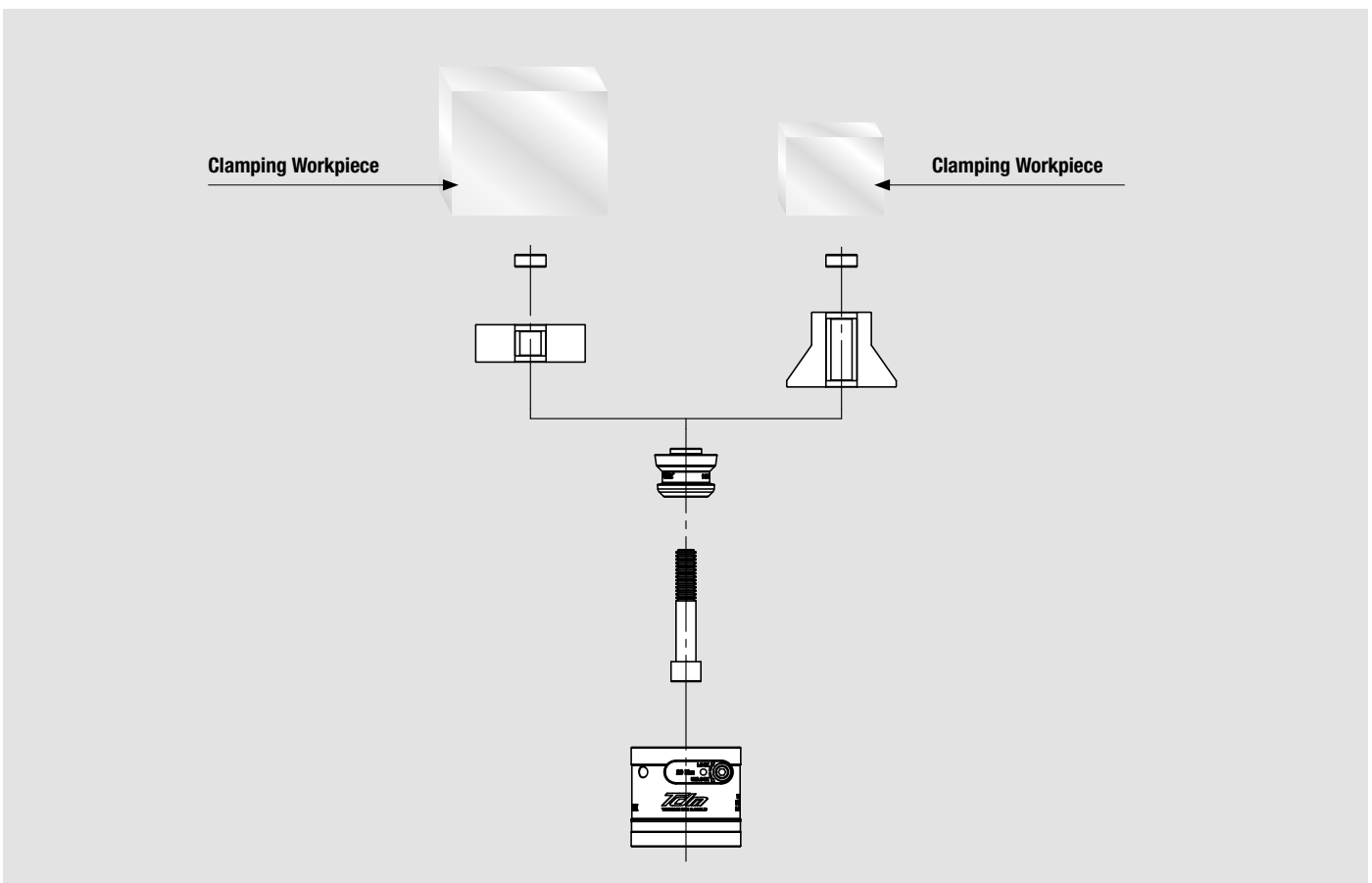

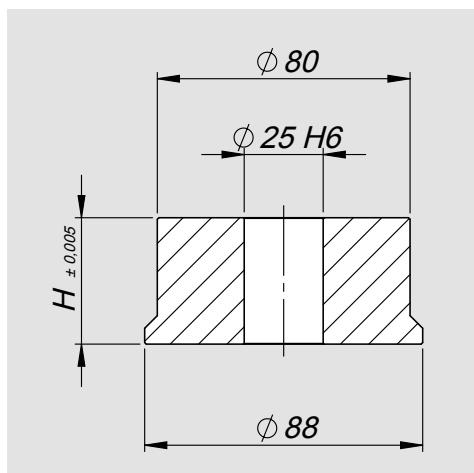
ADAPTOR FROM $\varnothing 88$ TO $\varnothing 80$ 

Id. No.	H
46232520	20
46232540	40
46232560	60

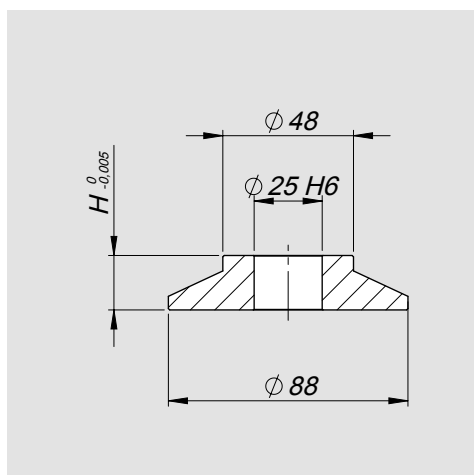
ADAPTOR FROM $\varnothing 88$ TO 48

Id. No.	H
46232620	20
46232630	30
46232640	40
46232650	50
46232660	60

THIRD POINT

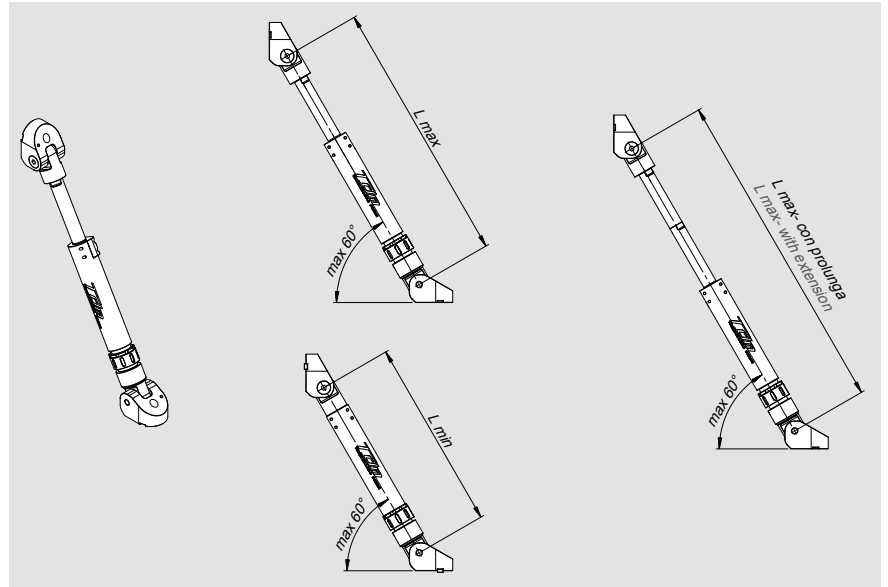

Id. No.	Lmin	Lmax	L max extension
46232110 *	614	850	1050

* Complete with sector wrench

MAGNET FOR THIRD POINT

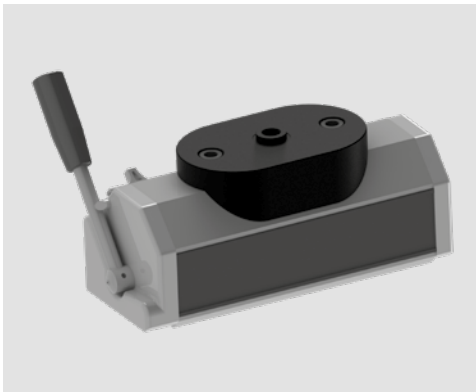

Id. No.
46232130

Working examples



EXTENSION



Id. No.
46232115

Working examples



ADAPTER FOR THIRD POINT

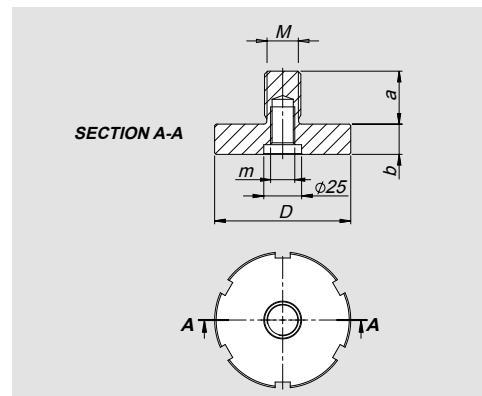
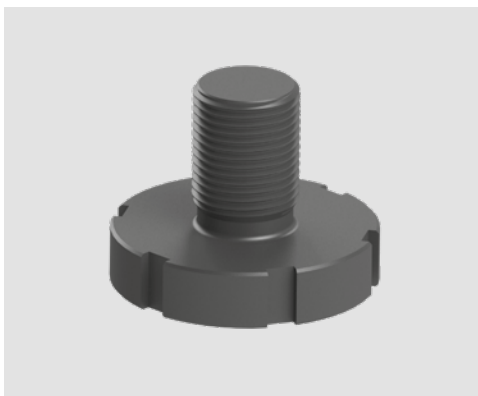

Id. No.	D	M	a	b	m
46232311	90	M24 x 3	35	20	M16
46232312	90	M30 x 3,5	40	20	M16
46232313	90	M36 x 3	50	20	M16
46232314	90	M36 x 4	50	20	M16
46232315	90	M 42 x 3	60	20	M16
46232316	90	M42 x 4,5	60	20	M16
46232317	90	M48 x 3	70	20	M16
46232318	90	M48 x 5	70	20	M16
46232319	90	M56 x 5	80	20	M16
46232320	90	M64 x 6	90	20	M16

Working examples

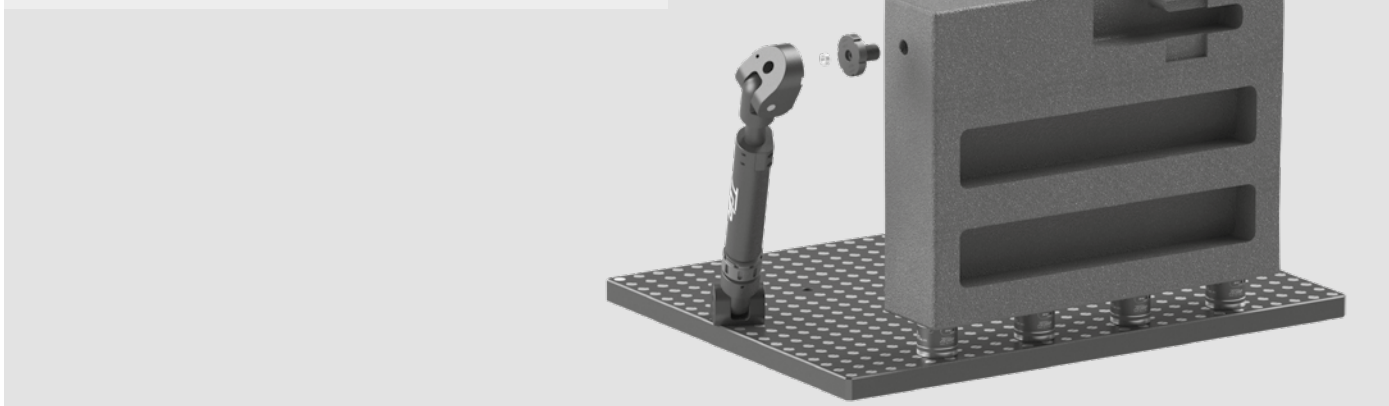

FIXING KIT FOR THIRD POINT FOR T-SLOTS



	Code for T-slots			
	mm 18	mm 20	mm 22	mm 24
Id.No.	46232141	46232142	46232143	46232144

COLLECT CHUCK ER50

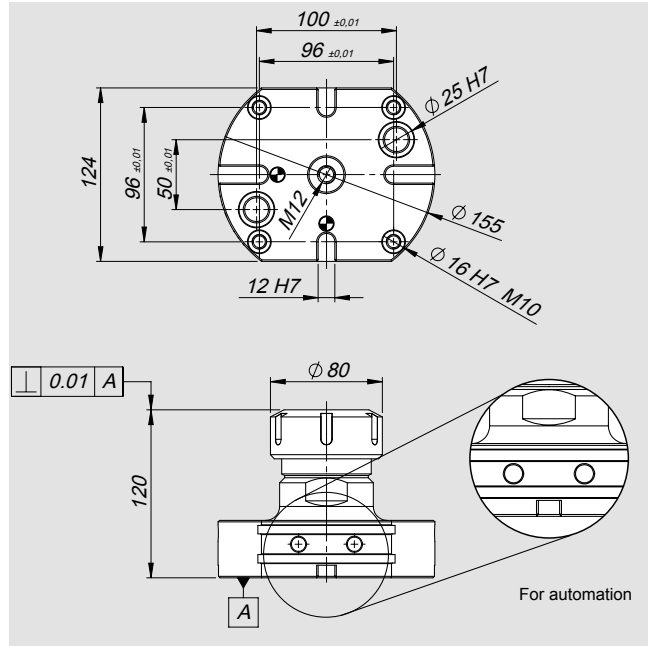

Id. No.
46233500

Working examples



MODULAR TOMBSTONE

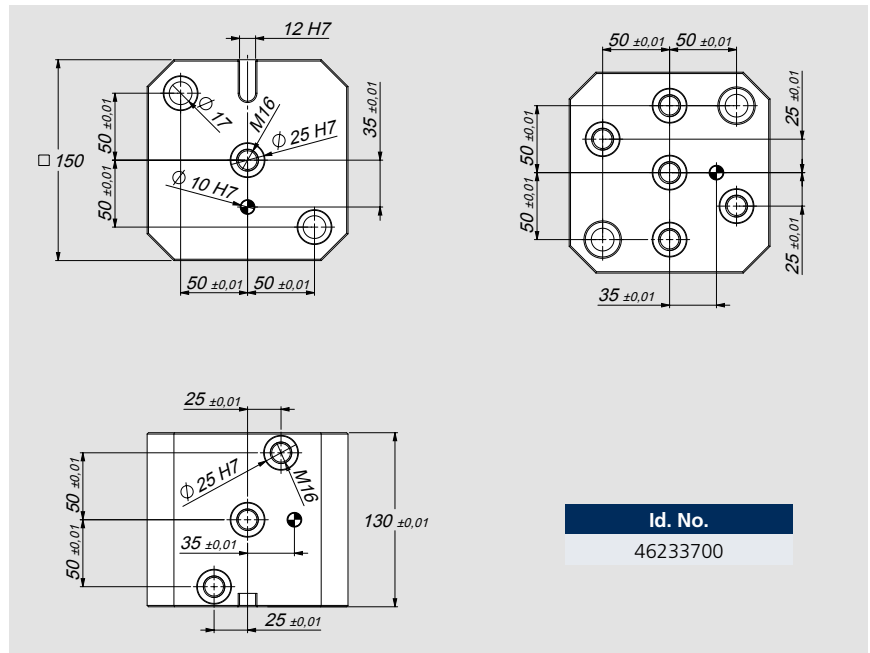

Id. No.

46233700

PAIR OF JAWS WITH CLAMPING SCREW TDM 88



Type	Id. No.
TDM 88 H40	46231001
TDM 88 H60-80-160	46231002

CLAMPING SCREW TDM 88



Type	Id. No.
TDM 88 H40	46230031
TDM 88 H60 - 80 - 100	46230032

TdM 48

TORQUE DIE & MOLD



Benefits



- ▶ Only 3.5 rotation Lock-Unlock
- ▶ High jaws surface contact
(Pull down force 8 Kn at 12 Nm)

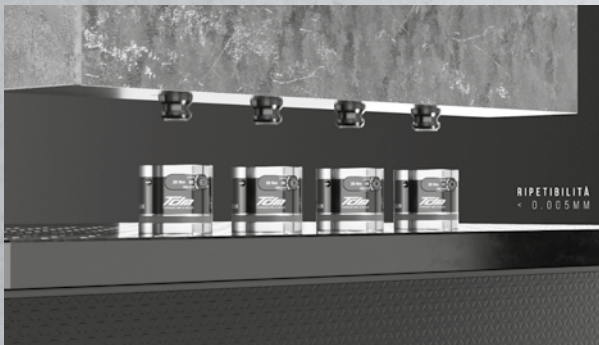

- ▶ Repeatability <0,005 mm
- ▶ Holding force up to 50 Kn



- ▶ Self centered self compensating jaws

TdM 48

TORQUE DIE & MOLD

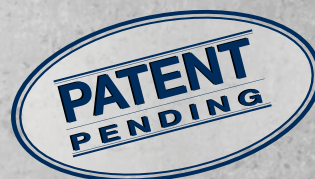



Application/Benefits

- Huge reduction of set-up times for highest efficiency
- Safe workpiece clamping with maximum holding forces and highest repeatability
- Ideal for 5-axis machining
- Single quick-actuation for the rapid opening and closing of the modules with only 3.5 rotations
- Flexible configurations for customized use
- Interchangeable to the proven zero point system APS

Technical features

- Diameter 48 mm
- Pull down force 8 kN
- Max. torque 12 Nm
- Repeatability < 0.005 mm
- Holding force up to 50 Kn
- 2 clamping slides for maximum hold while clamping
- Complete of special screw cod. 46230004
- Fully sealed - low maintenance

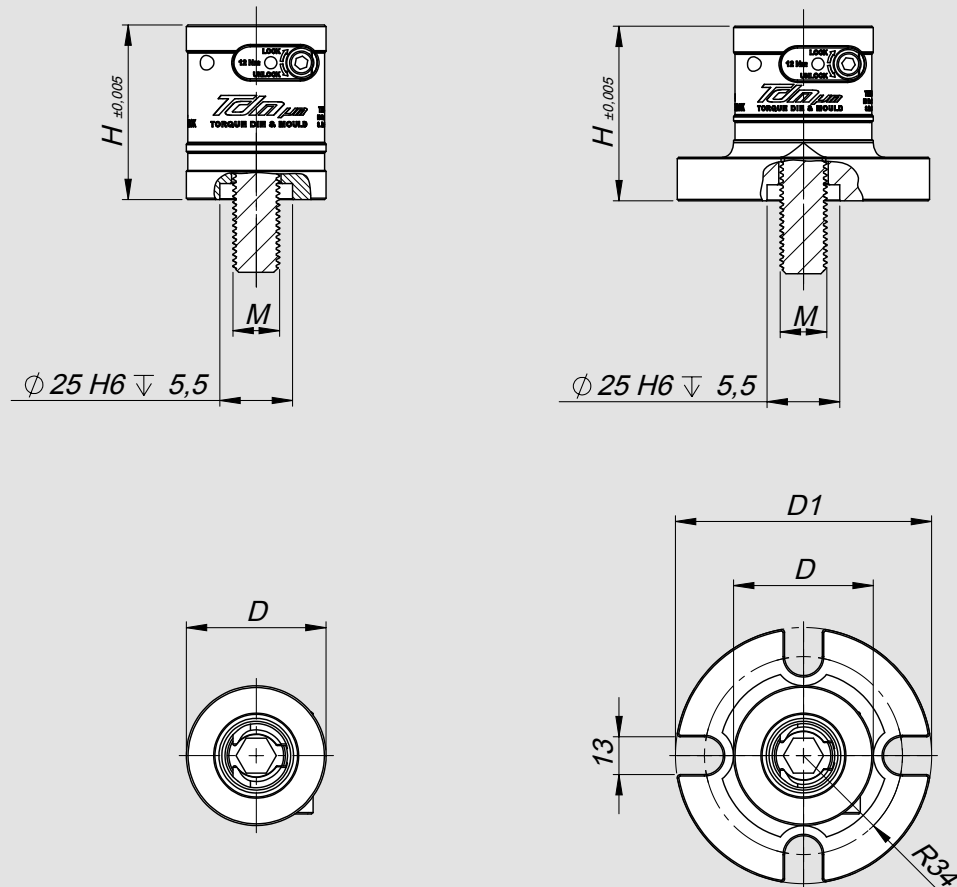

Module	Id. No.	D	D1	H	M
TDM 48	46230105	48	-	60	M16
TDM 48 flangiato 88/48	46230106	48	88	60	M16



Application/Benefits

- Huge reduction of set-up times for highest efficiency
- Safe workpiece clamping with maximum holding forces and highest repeatability
- Ideal for 5-axis machining
- Single quick-actuation for the rapid opening and closing of the modules with only 3.5 rotations
- Flexible configurations for customized use
- Interchangeable to the proven zero point system APS

Technical features

- Diameter 48 mm
- Pull down force 8 kN
- Max. torque 12 Nm
- Repeatability < 0.005 mm
- Holding force up to 50 Kn
- 2 clamping slides for maximum hold while clamping
- Complete of special screw cod. 46230004
- Fully sealed - low maintenance

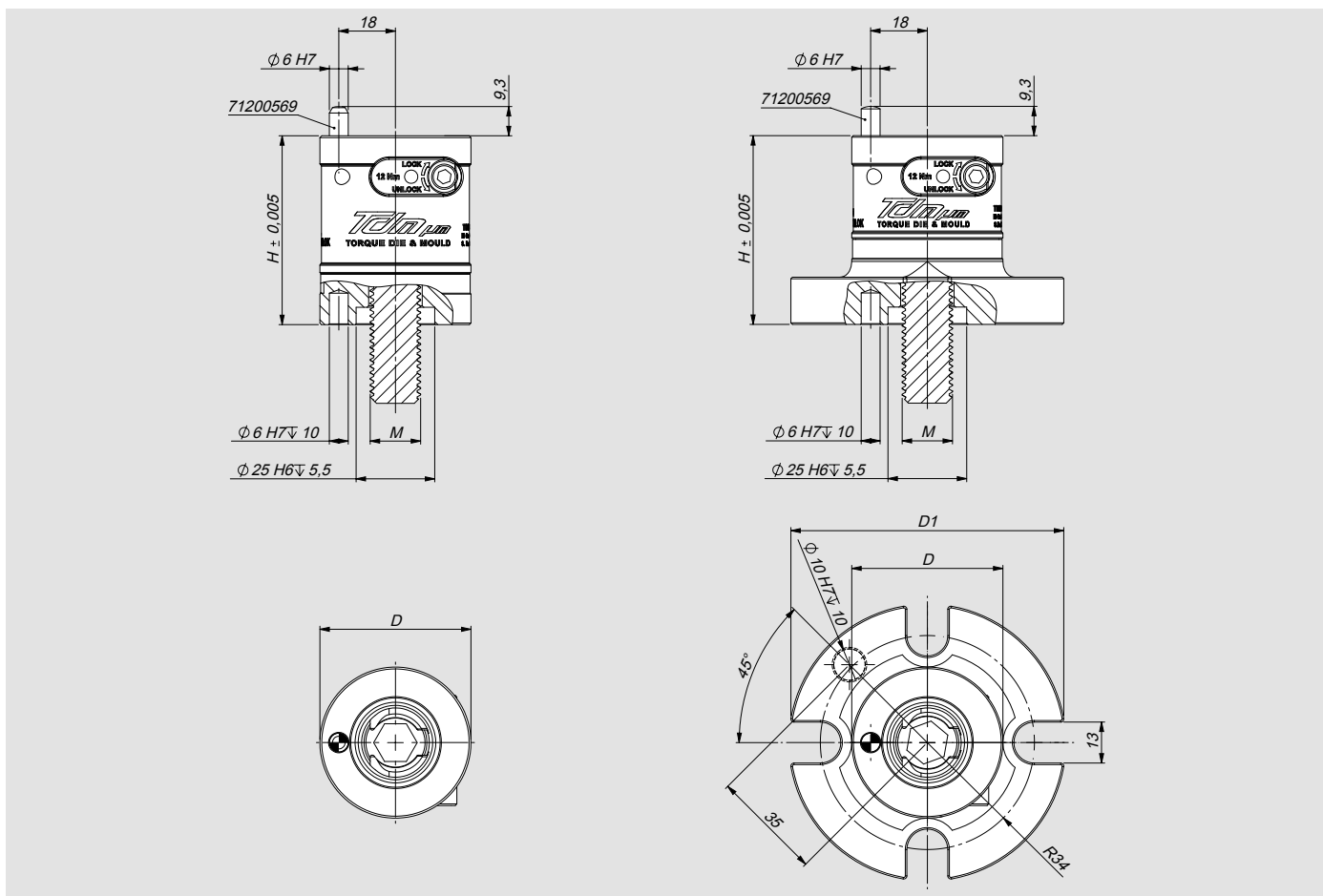

Module	Id. No.	D	D1	H	M
TDM 48 index	46230115	48	-	60	M16
TDM 48 index flangiato 88/48	46230116	48	88	60	M16

Pins for TDM Ø48 complete with grub screw UNI 5932

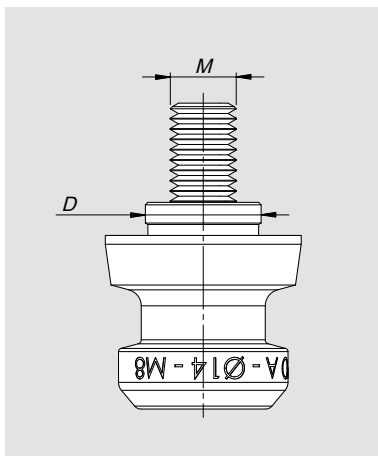

Id. No.	D	M - UNI 5932	Type
46231531	10 h4	M6	A
46231532	11 h4	M6	A
46231541	12 h4	M8	A
46231542	14 h4	M8	A
46231551	14 h4	M10	A
46231552	16 h4	M10	A
46231731	10 h4	M6	C
46231732	11 h4	M6	C
46231741	12 h4	M8	C
46231742	14 h4	M8	C
46231751	14 h4	M10	C
46231752	16 h4	M10	C

Pins for TDM Ø48 without centering complete with grub screw UNI 5932

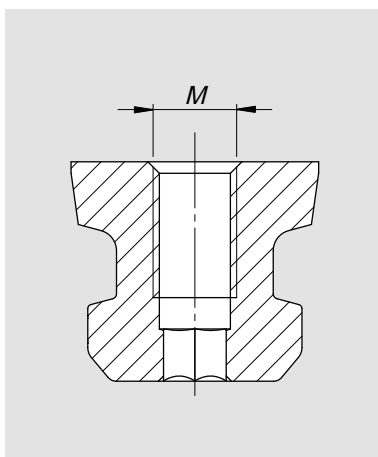

Id. No.	M - UNI 5932
46231533	M6
46231543	M8
46231553	M10

Special M16 clamping screw on grid plate



Id. No.
46230004

Working examples

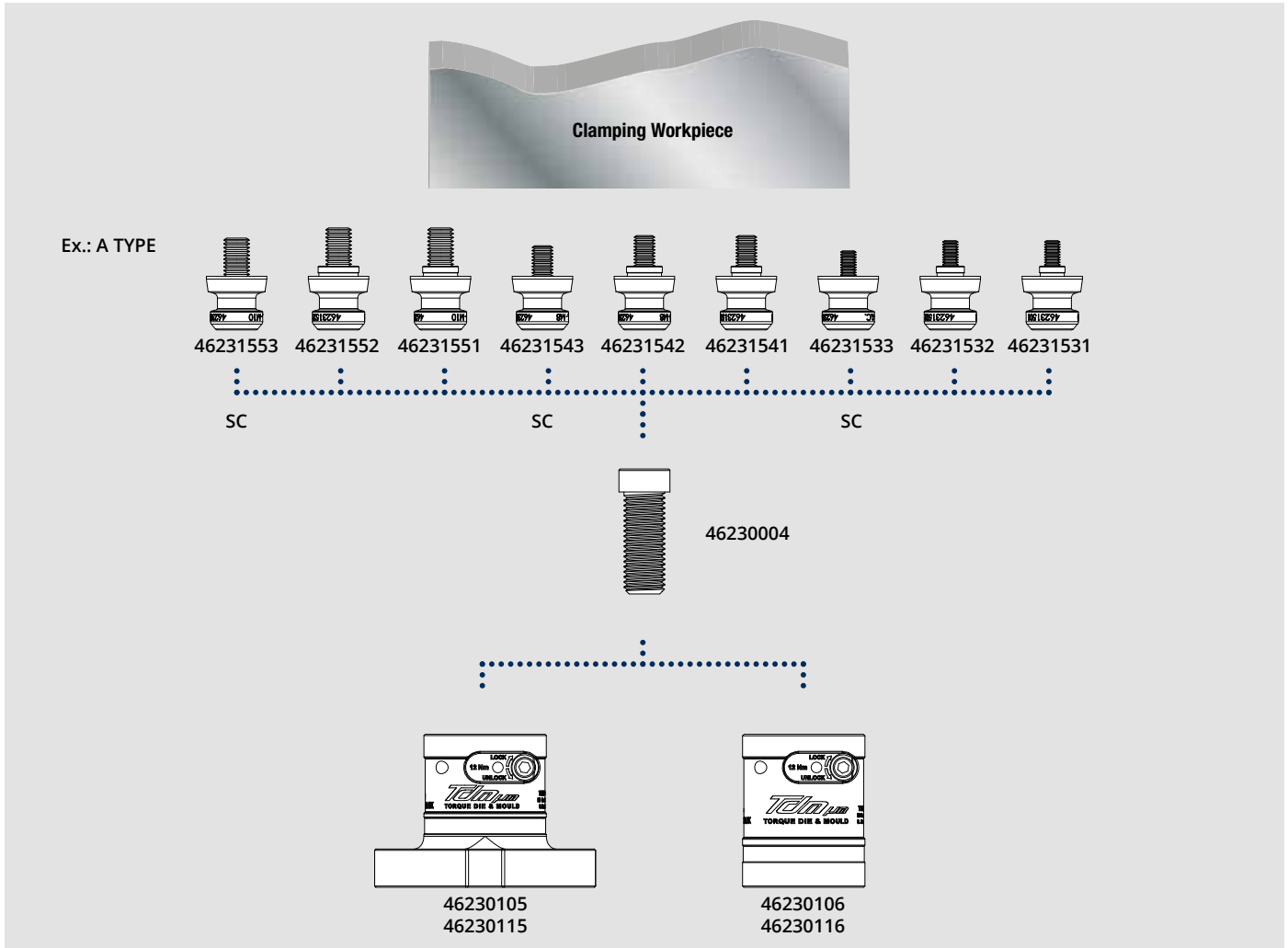

PAIR OF JAWS WITH CLAMPING SCREW TDM 48



Type	Id. No.
TDM 48	46231003

CLAMPING SCREW TDM 48



Type	Id. No.
TDM 48	46230033

REDUCTION BUSH for M12 / M10

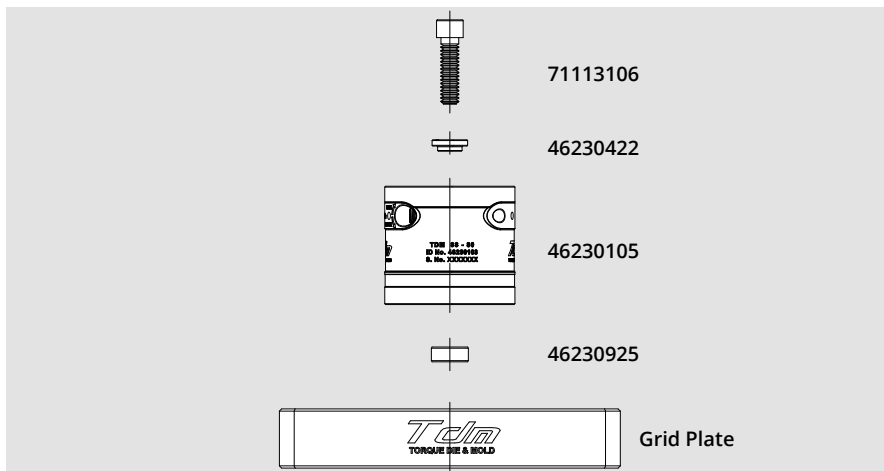
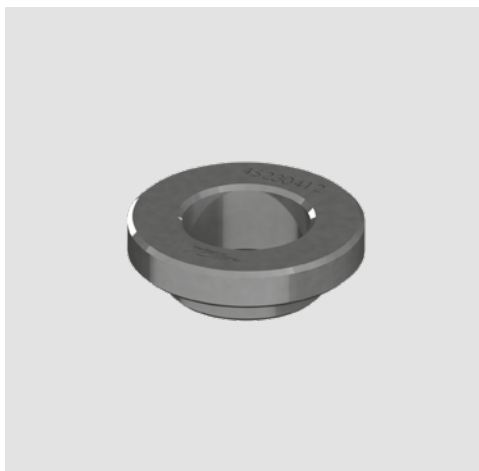

18- Reduction Mounting	M12			M10		
	Id. No. disk	Id. No. screw	screw length	Id. No. disk	Id. No. screw	screw length
TDM Ø48 H60	46230422	71113106	40	46230420	71113085	35

CENTERING BUSH

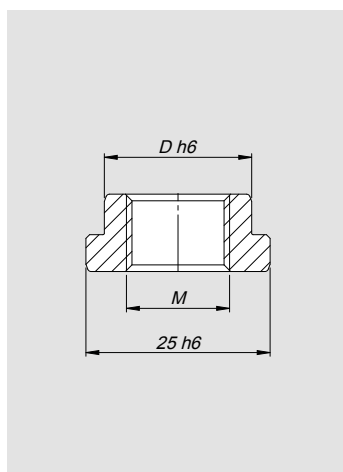

Id. No.	D	Thread for extraction *
46230918	18	M14 x 1,5
46230920	20	M14 x 1,5
46230922	22	M18 x 1,5
46230924	24	M18 x 1,5
46230925	25	M18 x 1,5

* Extractor page 0.1.44

SPACER for TDM Ø48

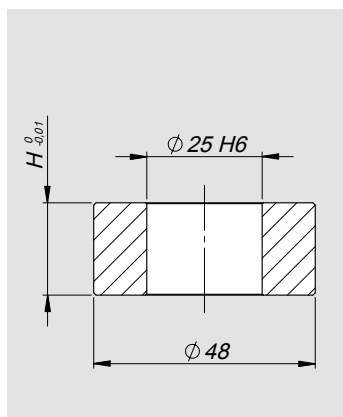

Id. No.	H
46232710	10
46232715	15
46232720	20
46232725	25
46232730	30
46232740	40
46232750	50

INTERFACE FLANGE for TDM 48/48

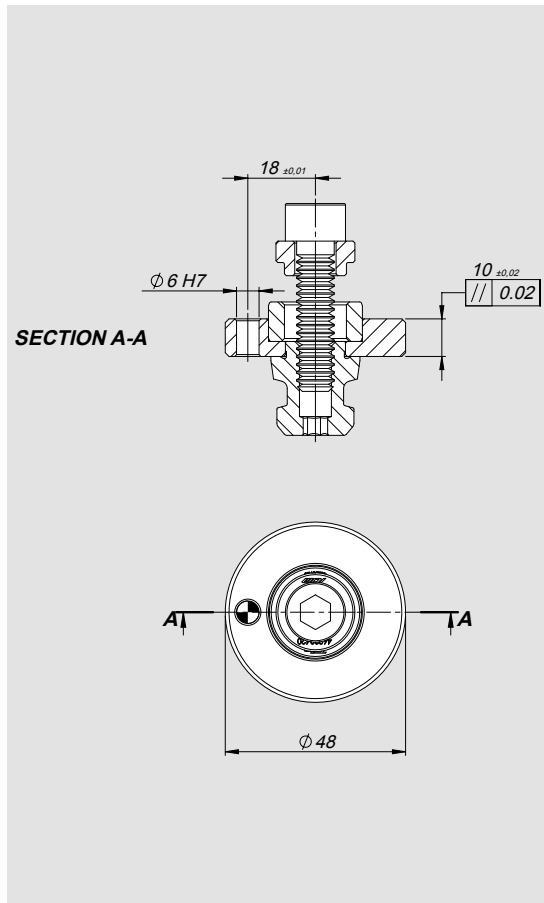

Id. No.
46234050

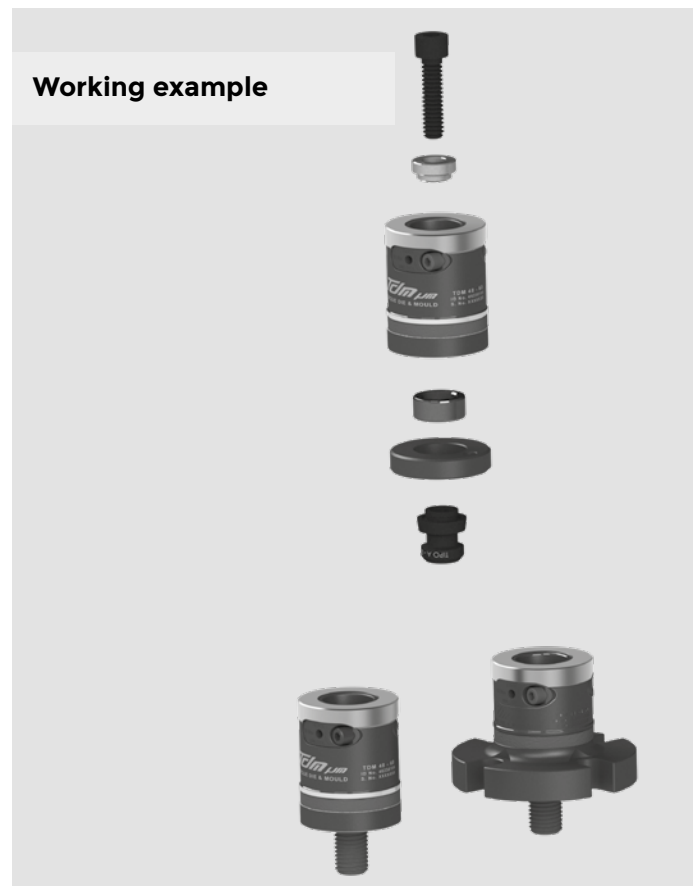



Magnetic system for clamping pieces in milling

Benefits

The **TDM MAG** system utilizes **MILLTEC AUTOBLOK MAG** technology in combination with the **TDM** system.

The clamping of the workpiece is carried out by means of the permanent electromagnetic system while the piece is centered through the **TDM MAG**.

A series of calibrated holes are made on the magnetic chuck with hardened bushes pitch 100mm ± 0.01 mm to which the **TDM MAG** elements are fixed.

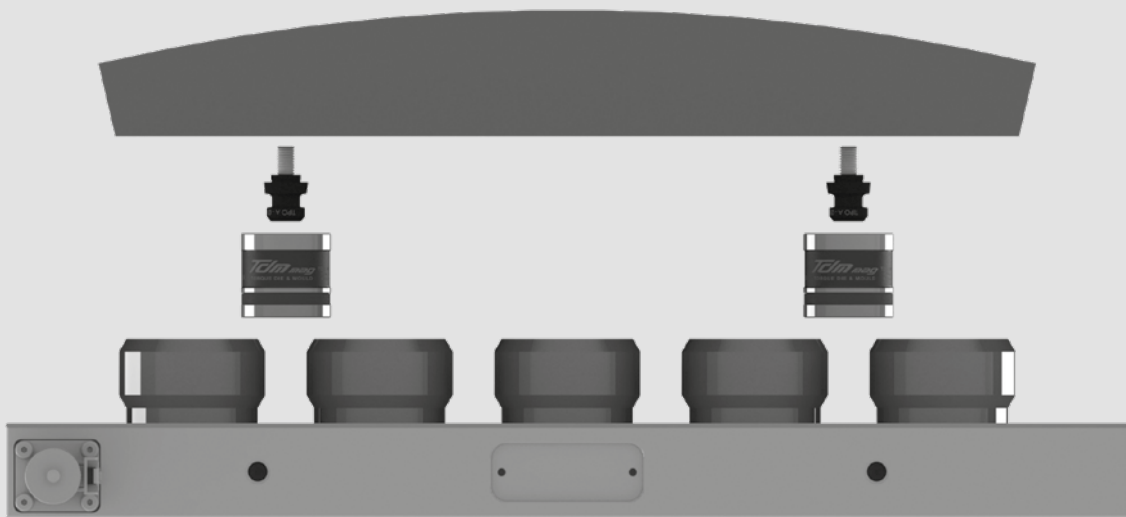

Location.

With **TDM MAG** the problem of the workpiece's location is solved and with **TDM** the possibility of workpiece sliding is eliminated during the machining.

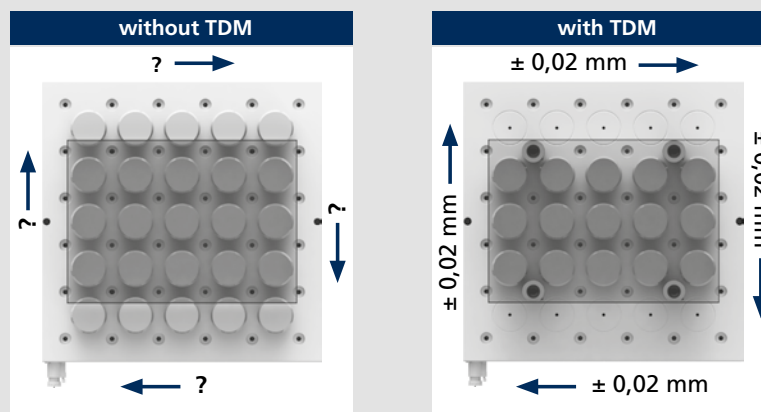

Magnetic system for clamping pieces in milling

Benefits

Repeatability.

With TDM MAG the positioning repeatability of the workpiece is guaranteed $\pm 0,01\text{mm}$.

Precision.

The magnetic plates of the TDM MAG series are finely ground within the indicated parallelism tolerance

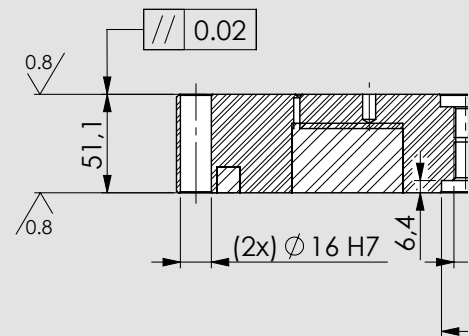

Roughness of the piece.

The magnetic clamping force of a workpiece is proportional to the contact surface and to the square of its magnetic flux density.

Consequently, to ensure a better clamping force, it is recommended to cover the largest number of North and South magnetic poles and above all to improve the quality of contact with the piece as much as possible through the use of suitable pole extensions and the choice of the correct magnetic generator.

Having carried out the first preparation phase of the piece (see point 2 of the cycle), **the best magnetic performance condition is consequently obtained.**

Factors Affecting Density of magnetic flux	Indicative values of performance reduction and application considerations
Roughness of the piece	<ul style="list-style-type: none"> 100% = rectified 90 ÷ 80% = fine milled (TDM MAG) 80 ÷ 70% = milled 70 ÷ 60% = raw
Type of material	<ul style="list-style-type: none"> 100% mild steel 70% ÷ 80% alloy steel 40% cast iron 0% non-magnetic stainless steel, brass, aluminum
Thickness of work-piece	The clamping of pieces with a thickness less than the minimum recommendation reduces the level of magnetic performance
Correct set up of the work-piece on the magnetic surface	It is preferable to place the piece partially covering more magnetic poles rather than a smaller number of magnetic poles with full coverage

TDM MAG

TORQUE DIE & MOLD



Magnetic system for clamping pieces in milling

Benefits

Zero Point

TDM MAG can be applied directly or via an interface plate (only for 400x400) to the APS Zero Point system.

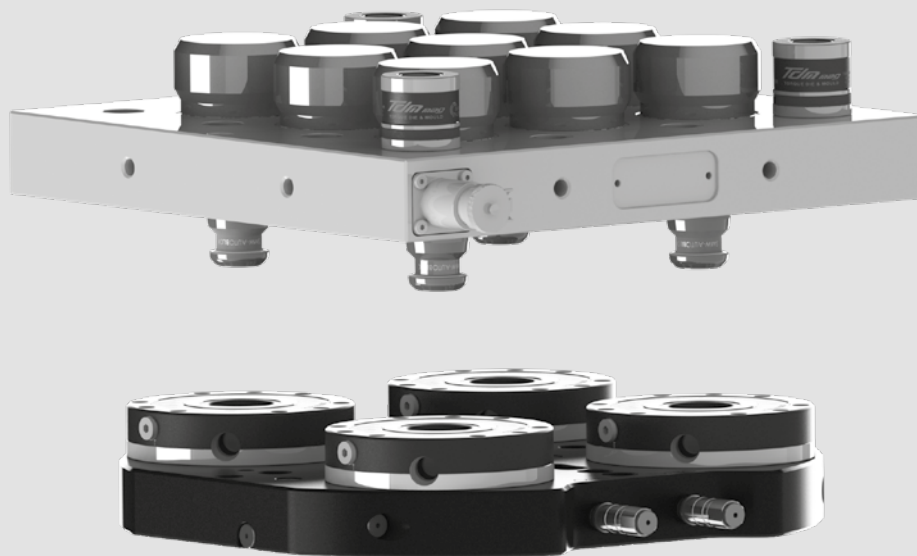

Non-magnetizable pieces

With TDM MAG, by replacing the centering modules (Id.No. 46233610) with the TDM 48 or 88 clamping modules, **NON-MAGNETIZABLE** pieces can be clamped with a considerable saving of set-up time.

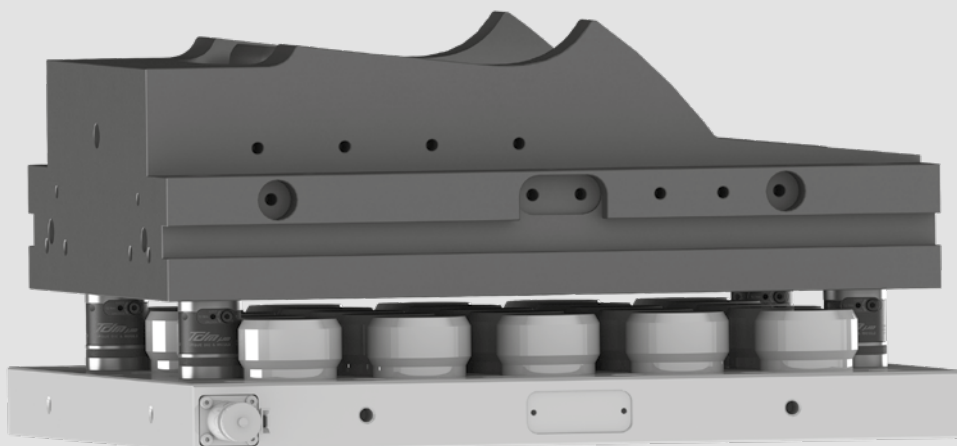

Polar extensions and automatic shimming

The use of polar extensions suitable for the application reduces the operating air gaps and improves the magnetic flux density. They can be used to elevate the piece and machine the 5 faces in a single placement, for contouring, chamfering, through drilling operations or to create mechanical, magnetic stops and dedicated jigs.

It is possible to carry out the automatic shimming of deformed pieces through the use of mobile extensions that avoid the tensioning of the piece during the work phase.

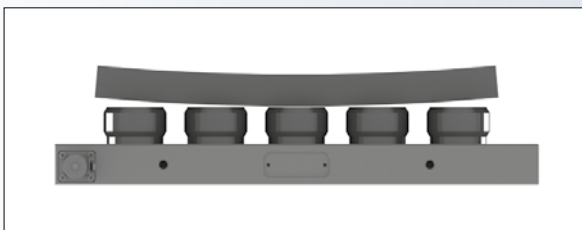

OP 1

Place the workpiece on 3 3 TDM centering elements (Id.No. 46233610) placed at the end to determine the work surface with the support of all the other mobile extensions.

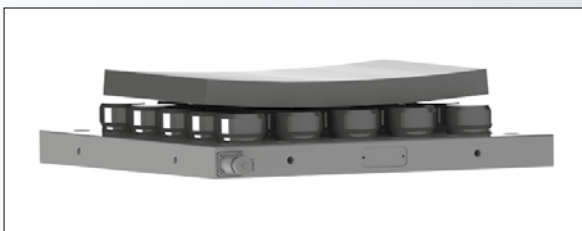

OP 2

By starting a magnetization cycle on the permanent-electro magnetic chuck, you will notice that the mobile pole extensions will adapt to the profile of the workpiece. At this point, start the first machining on the upper surface and drill the holes for the TDM pins (see page 38).

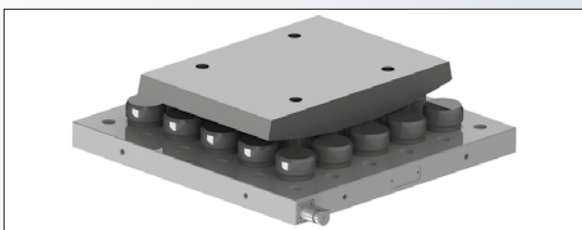

OP 3

Once the first machining is finished, start a Demagnetization cycle.

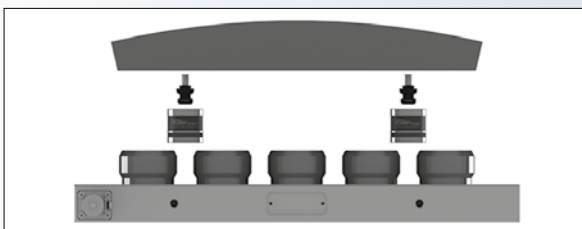

OP 4

Turn the workpiece upside down with the machined face on the bed of pole extensions. Start the magnetization cycle for the second machining operation.

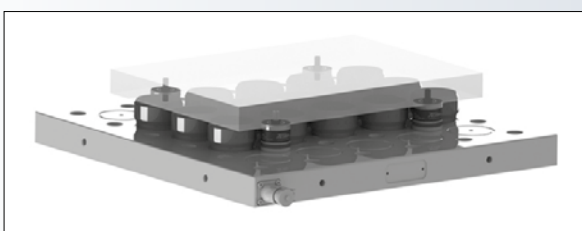

OP 5

At the end of the second machining it is possible to proceed with a demagnetization cycle, then remove the perfectly planar machined piece with the two parallel faces.

TDM MAG

TORQUE DIE & MOLD



Magnetic system for clamping pieces in milling

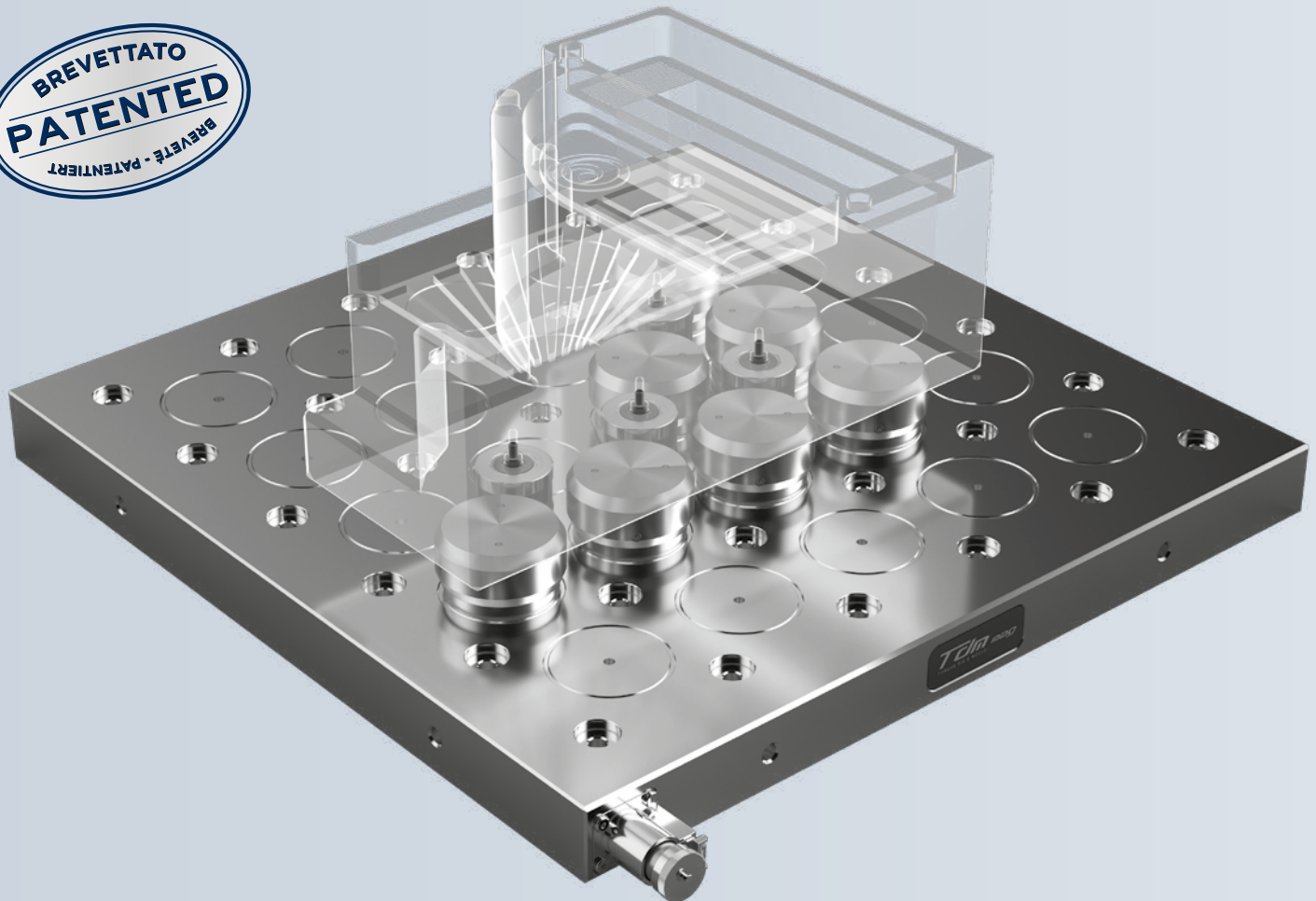

TDM system integrated with the technology of the subsidiary MAG AUTOBLOK

MILITEC is a MAG AUTOBLOK TECNOMAGNETE patent and represents the state of the art in the technological and constructive evolution of electro-permanent magnetic chucks for machining centers and milling machines.

The frame is designed as a monolithic honeycomb structure and manufactured "from solid" with the same technology used for precision molds.

The entire surface can be machined for the insertion of precision bushings, dowel pins or mechanical and magnetic stops to be used as a reference or to enhance the clamping force.

All of the magnetic and electrical components are inserted inside the frame in a special housing becoming an integral and solid part of the system.

The magnetic poles are the result of a series of coring machining carried out from the lower side of the monoblock steel frame and highlighted on the upper working side by light circular engravings.

The working surface is totally metallic without any presence of epoxy resin, brass or aluminum inserts.

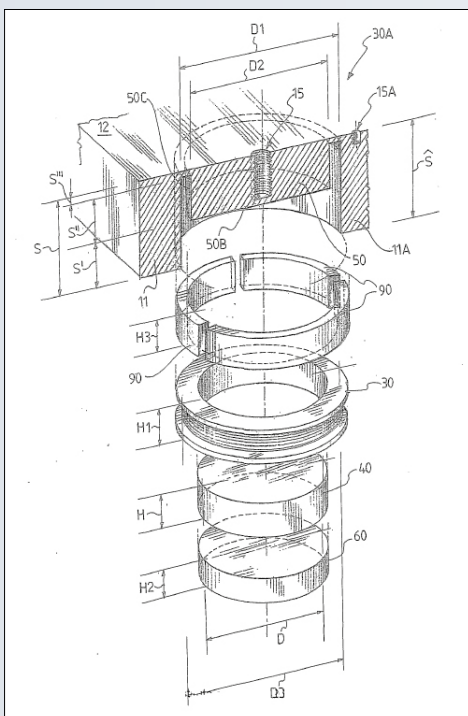
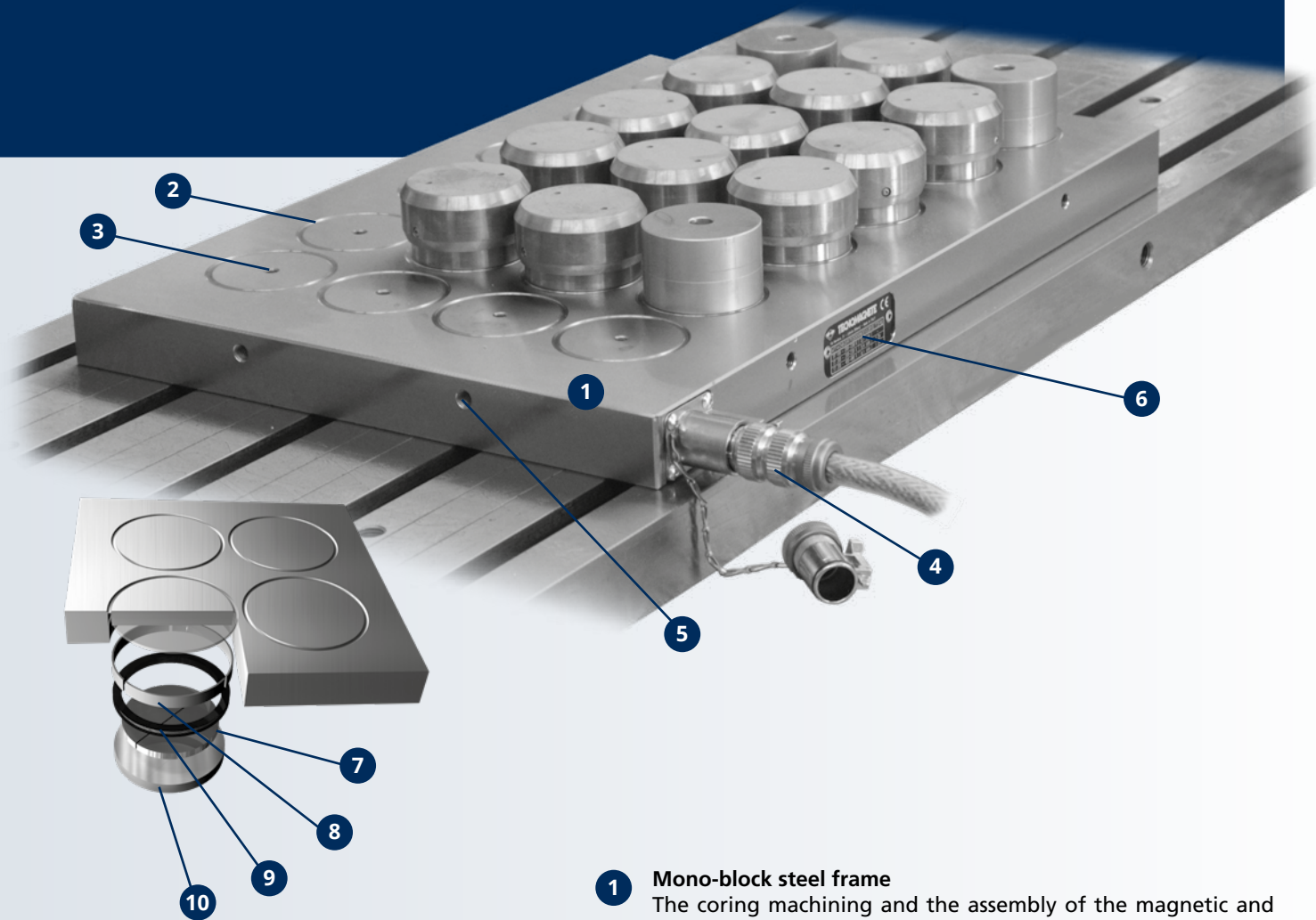

International patent WO 2009/130721

- 1 Mono-block steel frame**
The coring machining and the assembly of the magnetic and electric circuit from the lower create an impenetrable shield from any external agent.
- 2 Light circular engravings**
To highlight the position of the magnetic polarity while maintaining a totally solid and metal surface without resin, brass or aluminum inserts.
- 3 M8 threaded holes**
For the use of fixed / mobile extensions or special accessories tailored to the applicatio
- 4 Quick fit connector**
Precise, safe and watertight for quick connection with the control unit.
- 5 M10 threaded holes**
To use with mechanical stops for reference.
- 6 Performance plate with technical data**
Data on voltage, current absorption, serial number.
- 7 Reversible permanent magnet AlNiCo**
- 8 Static permanent magnet Neodymium**
- 9 Encapsulated electric coil**
- 10 Hermetic closing cap**

MAGNETIC PLATE

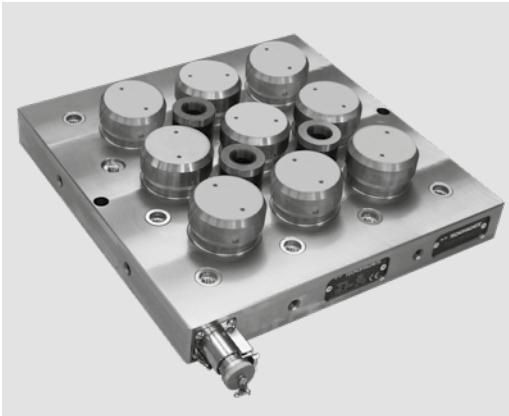

Complete with:

- Magnetic plane
- n. 9 moving extensions
- n. 3 TDM MAG (46233610)
- ST200FA control unit
- Cable

(Pins not included)

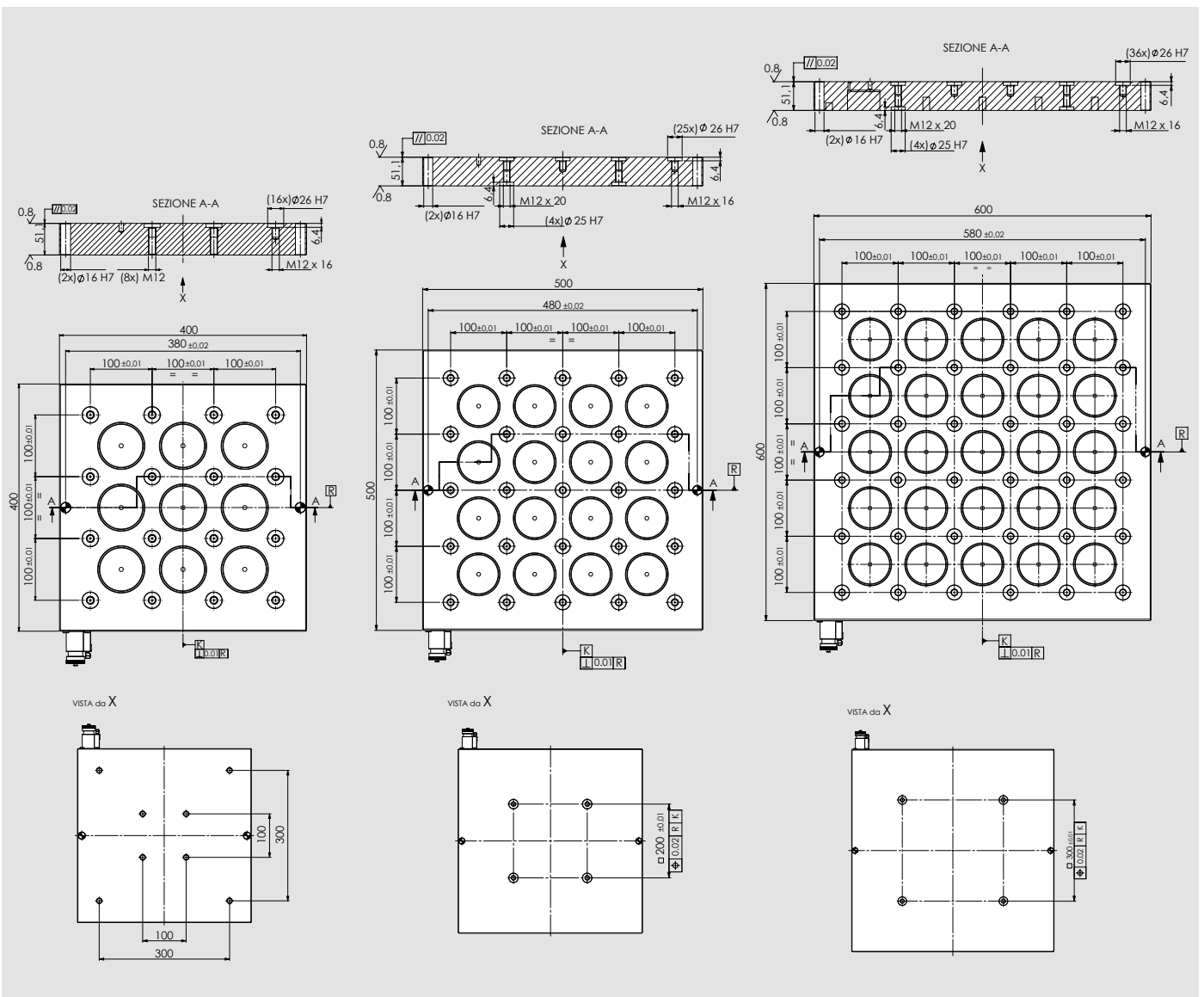

Id. No.	Dimensions	Weight	Poles	Min. thicks	Force/pole	Force
	mm	Kg	n.	mm	daN	Tons
46233640 *	400 x 400 x 51	90	9	17	615	5,8
46233650	500 x 500 x 51	120	16	17	615	10
46233660	600 x 600 x 51	155	25	17	615	16

* Integration for Zero Point pins with interface plate

On request: magnetic plates of different dimensions

TDM MAG 48 - Centering module with screw

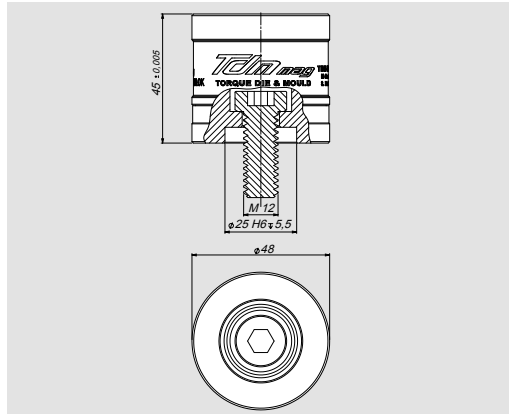

Id. No.
46233610

TDM 48 - For clamping non-magnetizable pieces

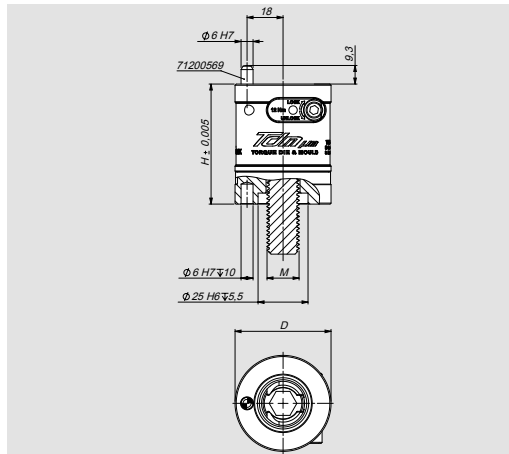

See page 0.1.24
for technical features

Module	Id. No.	D	H	M
TDM 48	46230105	48	60	M16

TDM 88 - For clamping non-magnetizable pieces

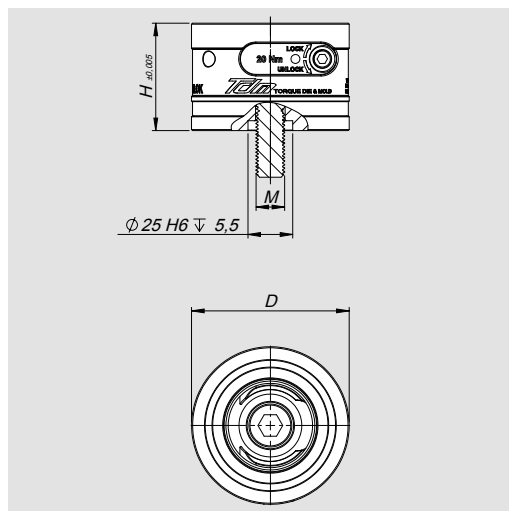

See page 0.1.6
for technical features

Module	Id. No.	D	H	M*
TDM88 H60	46230102	88	60	M16 **
TDM88 H80	46230103	88	80	M16 ***
TDM88 H160	46230104	88	160	M16 ****

* Complete with screw 12.9

** TCEI-BAS M16x40 UNI 9327 DIN 7984 (Thin head cap screw)
*** TCEI M16x50 - **** TCEI M16x110

Pins for TDM Ø48 complete with grub screw UNI 5932

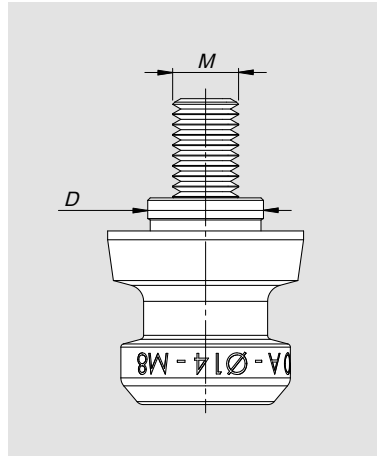

Id. No.	D	M - UNI 5932	Type
46231531	10 h4	M6	A
46231532	11 h4	M6	A
46231541	12 h4	M8	A
46231542	14 h4	M8	A
46231551	14 h4	M10	A
46231552	16 h4	M10	A
46231731	10 h4	M6	C
46231732	11 h4	M6	C
46231741	12 h4	M8	C
46231742	14 h4	M8	C
46231751	14 h4	M10	C
46231752	16 h4	M10	C

Pins for TDM Ø48 without centering complete with grub screw UNI 5932

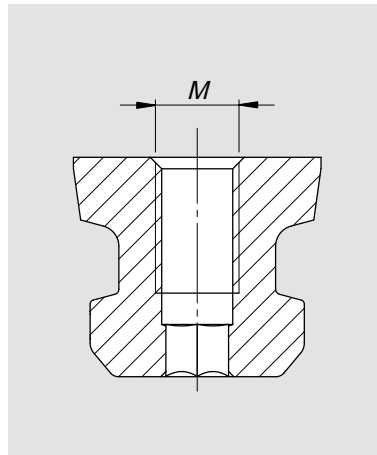

Id. No.	M - UNI 5932
46231533	M6
46231543	M8
46231553	M10

WORKPIECE PREPARATION

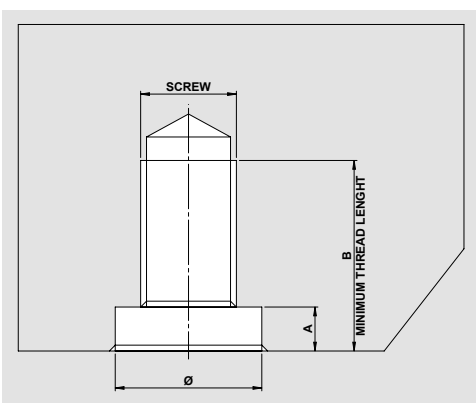

Screw	Ø	A	B Steel	B Cast Iron / Alloy
M6*	10-11 mm H6	5,5	16 mm	20 mm
M6	10-11 mm H6	5	16 mm	20 mm
M8*	12-14 mm H6	5,5	20 mm	27 mm
M8	12-14 mm H6	5	20 mm	27 mm
M10*	14-16 mm H6	5,5	22 mm	29 mm
M10	14-16 mm H6	6	22 mm	29 mm

* For TDM 48 range

APS interface plate for magnetic plate 400x400

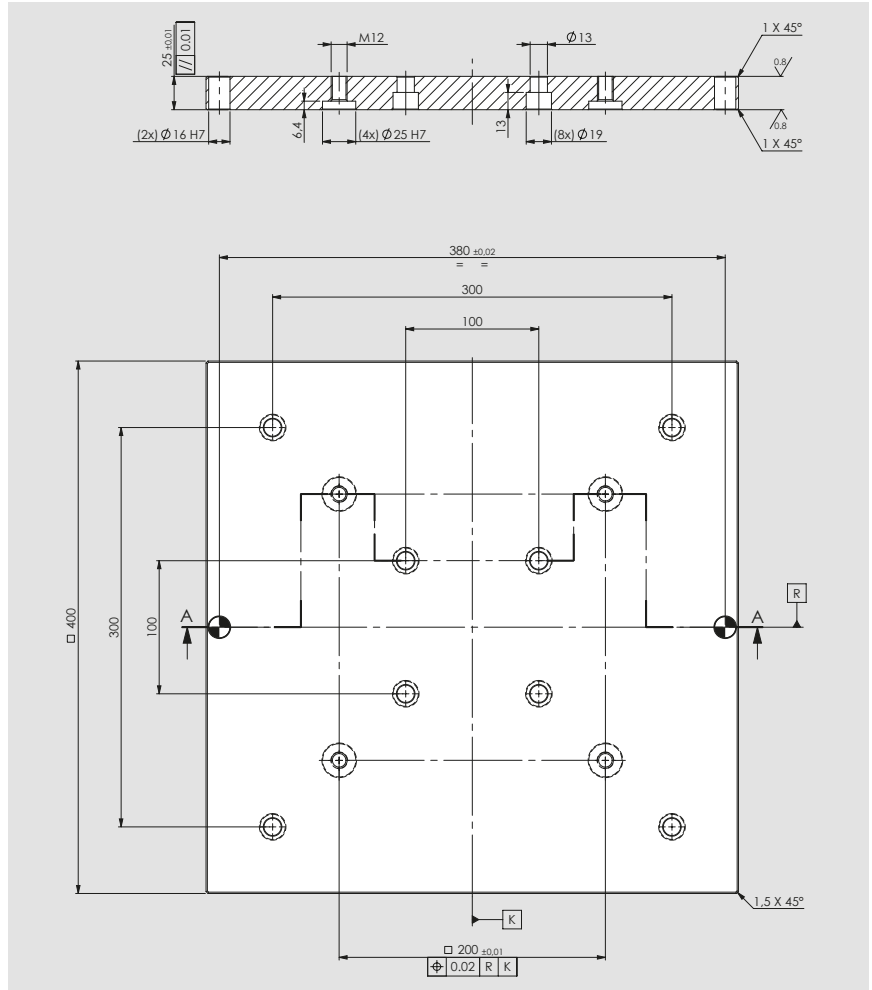
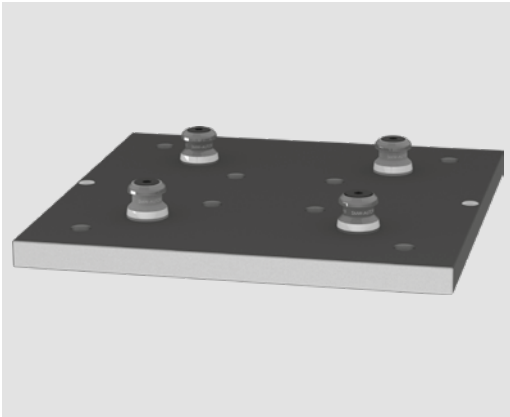

Integration interface plate for Zero Point pins complete with n. 1 pin A, n. 1 pin B, n. 2 pins C M12 for APS

Id. No.
46233645

Working example

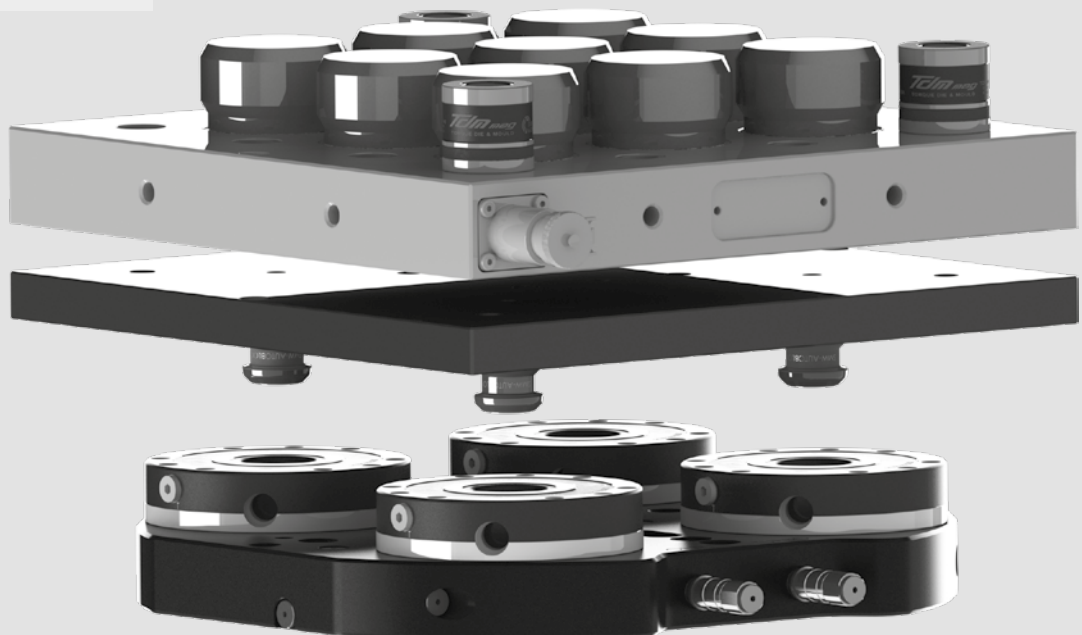

REDUCTION BUSH*

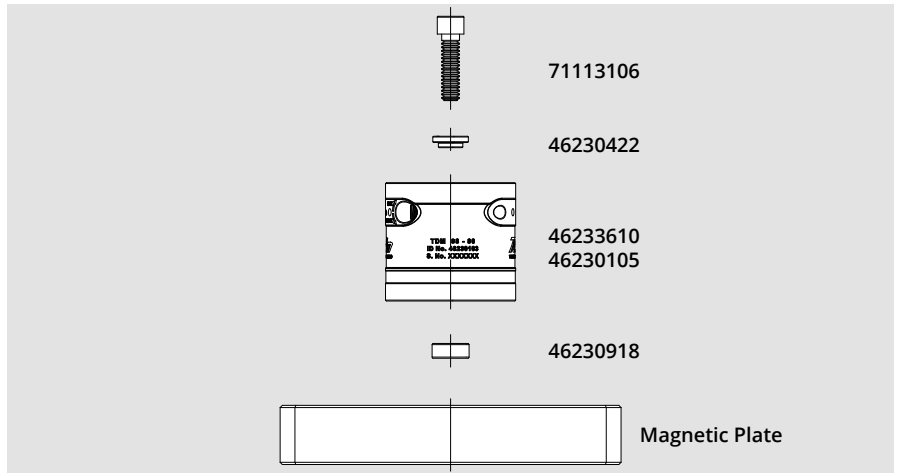
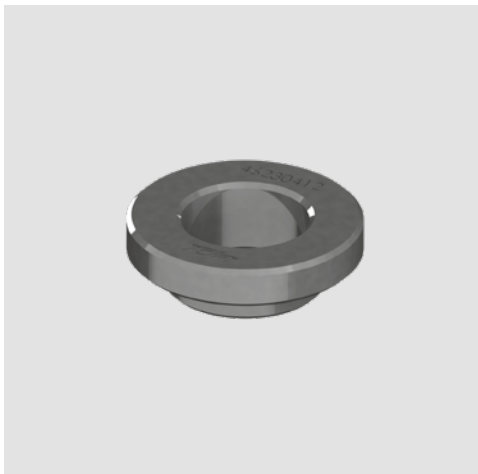

18- Reduction Mounting	M12		
TDM Ø48 H60	Id. No. disk	Id. No. screw	screw length
	46230422	71113106	40

* Required only for TDM 48 Clamping module (Id. No. 46230105)

CENTERING BUSH

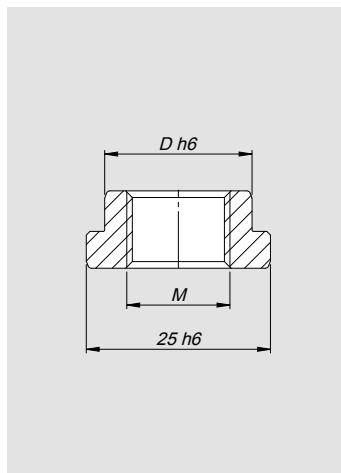

Id. No.	D	M
46230918	18	M14 x 1,5

CONTROL UNITS ST200FA



The ST200FA series is characterized by compactness and lightness.

Designed to be positioned vertically on the machine cabinet, it is supplied pre-arranged with a rear hooking system.

ST200FA has an integrated push button with high intensity LEDs and is available with voltages from 360V to 480V.

EXTENSION

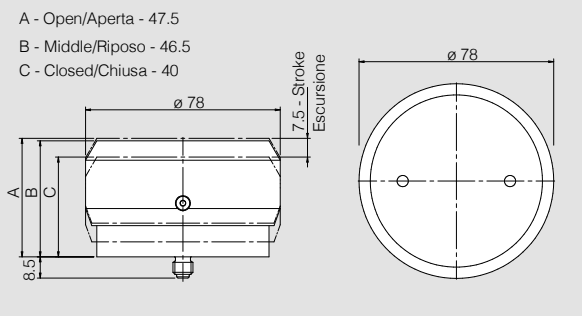
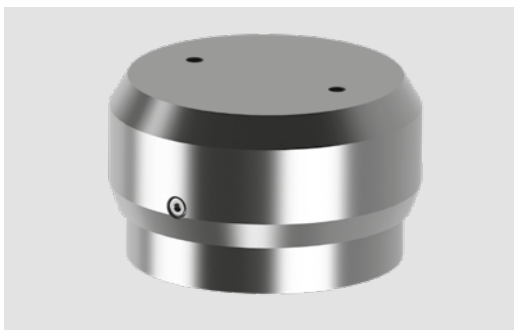

Id. No.
APRMP7045

FIX EXTENSION

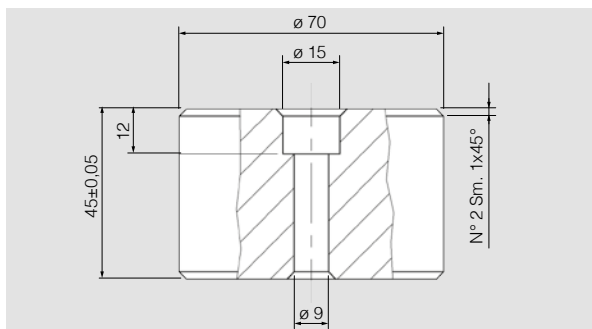
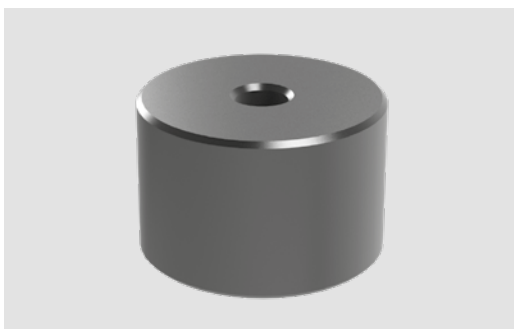

Id. No.
PFR70-45

CRANKWEBS

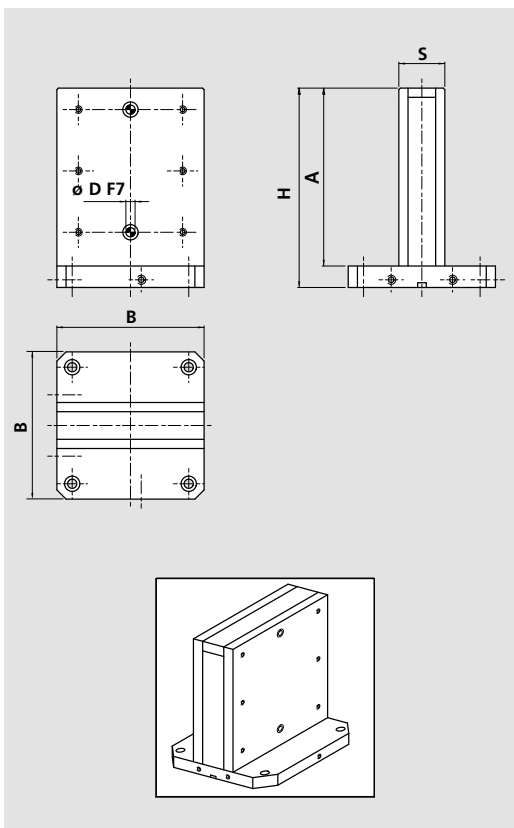

Working example

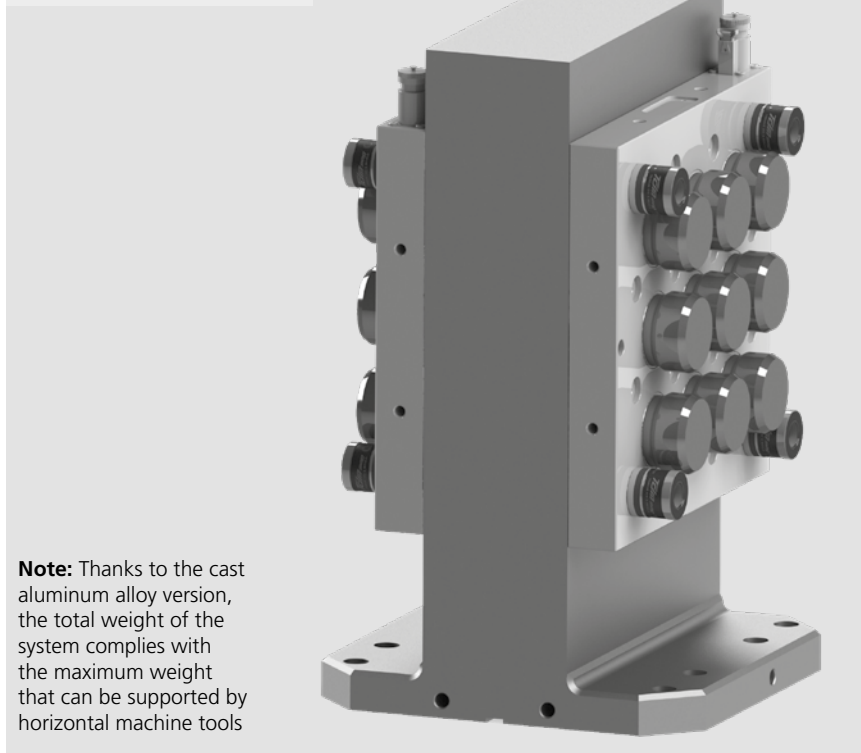

Note: Thanks to the cast aluminum alloy version, the total weight of the system complies with the maximum weight that can be supported by horizontal machine tools

Id.No.	A mm	B mm	H mm	Ø D mm	S mm	Weight Kg
57328035	620	400	660	16	150	77
57328055	660	500	700	16	150	103

Special sizes on request.

ROUNDED PLATES

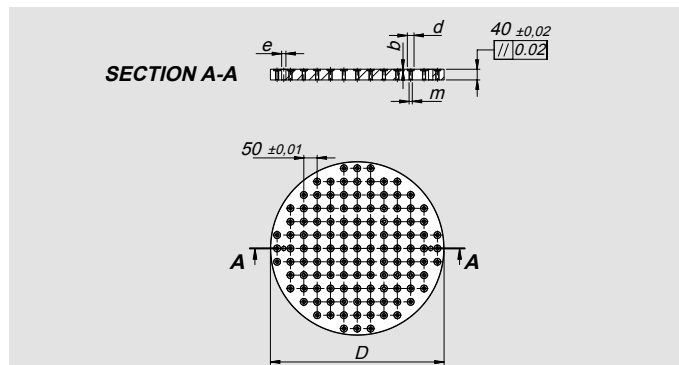

Id. No.	D	d	m	b	e	No. holes
46234122	Ø500	25 H7	M16	5,5	16H7	69
46234123	Ø650	25 H7	M16	5,5	16H7	121
46234124	Ø800	25 H7	M16	5,5	16H7	185

STANDARD PLATES WITH GRID

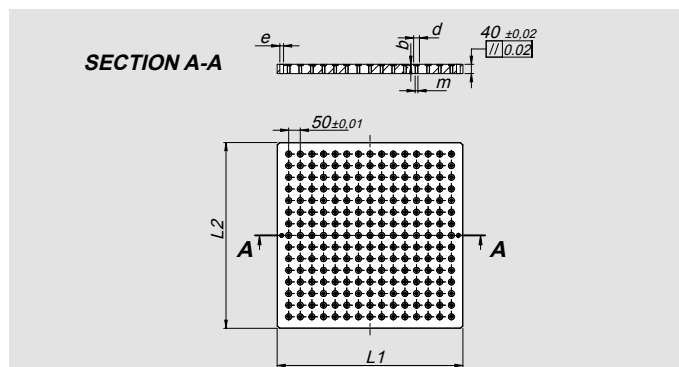
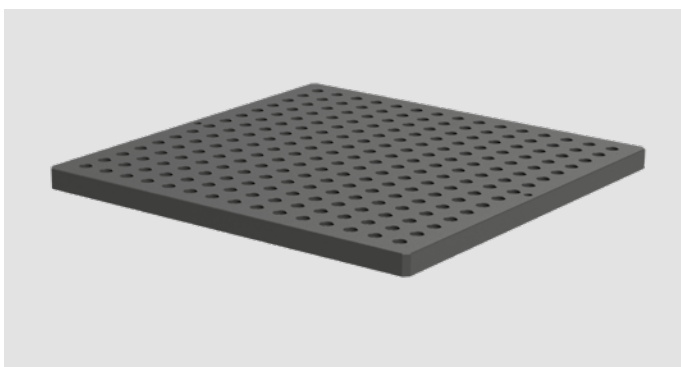

Id. No.	L1	L2	d	m	b	e	No. holes
46234102	499	499	25 H7	M16	5,5	16H7	81
46234103	599	599	25 H7	M16	5,5	16H7	121
46234104	799	799	25 H7	M16	5,5	16H7	225
46234105	999	499	25 H7	M16	5,5	16H7	171
46234106	999	999	25 H7	M16	5,5	16H7	361

MODULAR PLATES

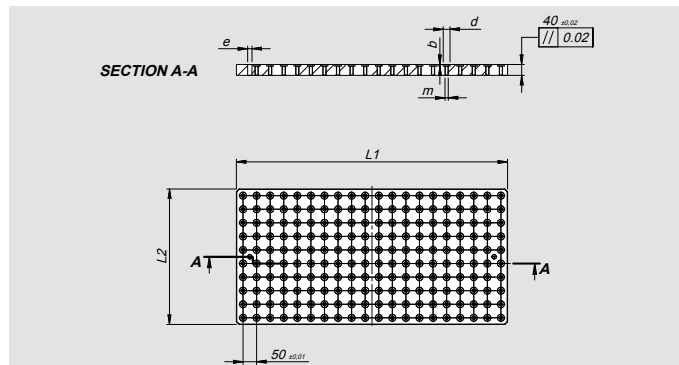
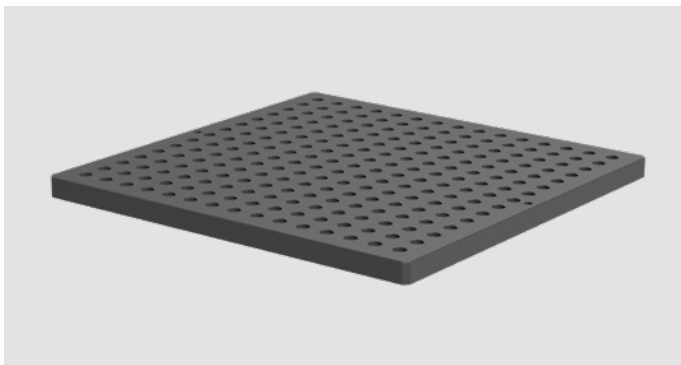

Id. No.	L1	L2	d	m	b	e	No. holes
46234112	499	499	25 H7	M16	5,5	16H7	100
46234113	599	599	25 H7	M16	5,5	16H7	144
46234114	799	799	25 H7	M16	5,5	16H7	256
46234115	999	499	25 H7	M16	5,5	16H7	200
46234116	999	999	25 H7	M16	5,5	16H7	400

GUIDE PLATES

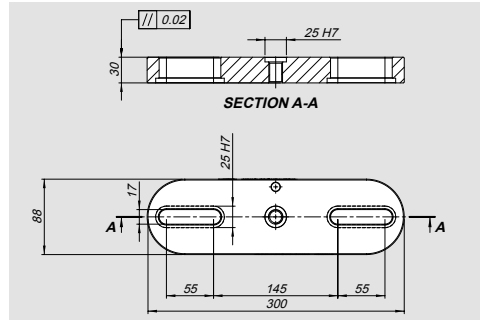

Id.No.	
for TDM 88	46232210

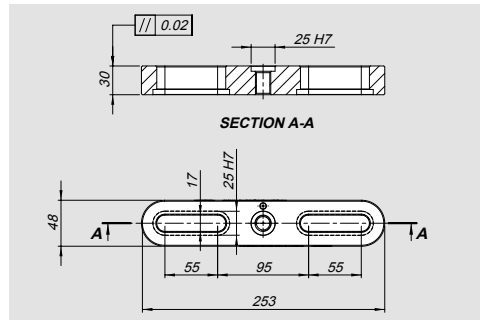

Id.No.	
for TDM 48	46232220

COMPASS PLATES

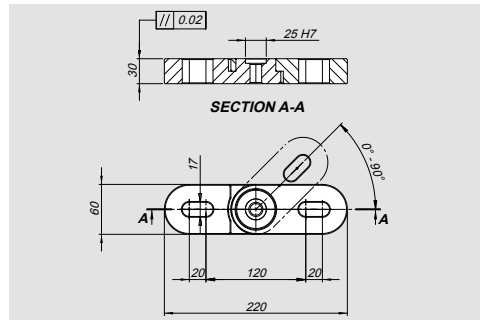

Id.No.	
for TDM 48	46232230

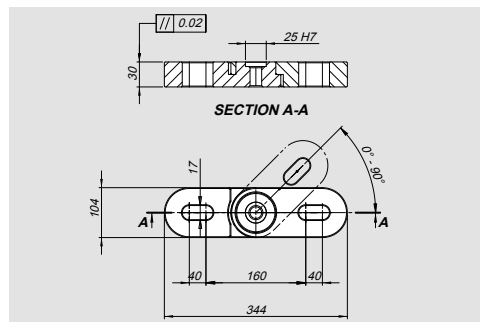

Id.No.	
for TDM 88	46232240

Working example

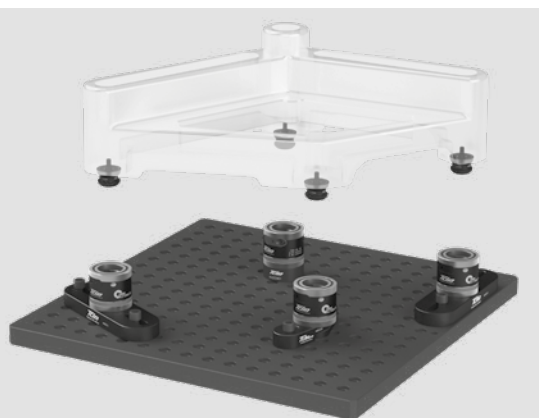

EXTRACTOR



Id. No.
46232150

REDUCTION FOR EXTRACTOR



Id. No.	H
46232153	M18 x 1.5
46232154	M12 x 1.5
46232155	M12
46232156	M10
46232157	M8
46232158	M6

CENTERING BUSH

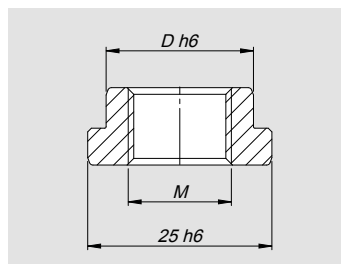
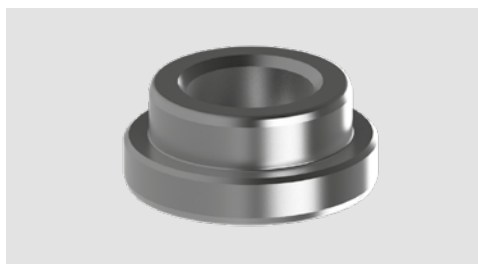

Id. No.	D	Thread for extraction * M
46230918	18	M14 x 1,5
46230920	20	M14 x 1,5
46230922	22	M18 x 1,5
46230924	24	M18 x 1,5
46230925	25	M18 x 1,5

* Extractor Id.No. 46232150

MULTI-SLOT SCREW FOR THE POSITIONING OF CLAMPING UNITS

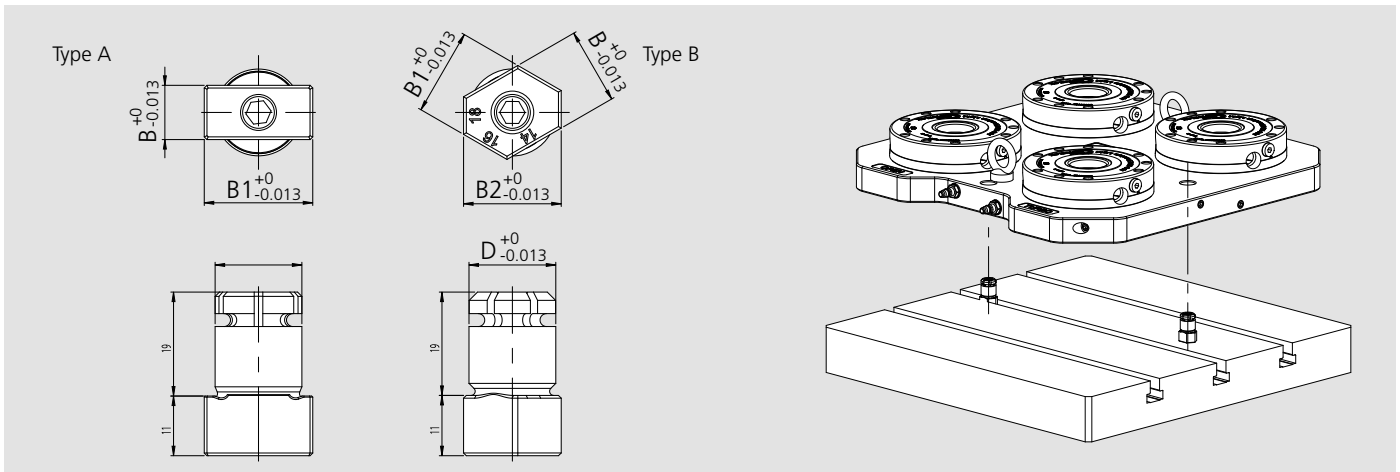

Type	Id. No.	DB	B	B1	B2	Ø
A: Multi-slot	71290183	16	10	20	-	16.01
A: Multi-slot	71290181	16	12	22	-	16.01
B: Multi-slot	71290182	16	14	16	18	16.01
B: Multi-slot	71290184	20	24	28	32	20.01

ALUMINIUM THREADED PLUG FOR GRID PLATES



Type	Id. No.
Aluminium threaded plug Ø 25 M16	57602397
Aluminium threaded plug Ø 24 M16	71290657

ROUNDED MINIPALLET

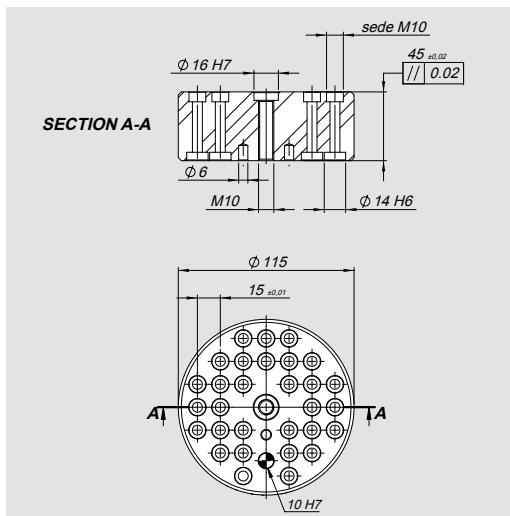

Id. No.
46233111

SQUARE MINIPALLET

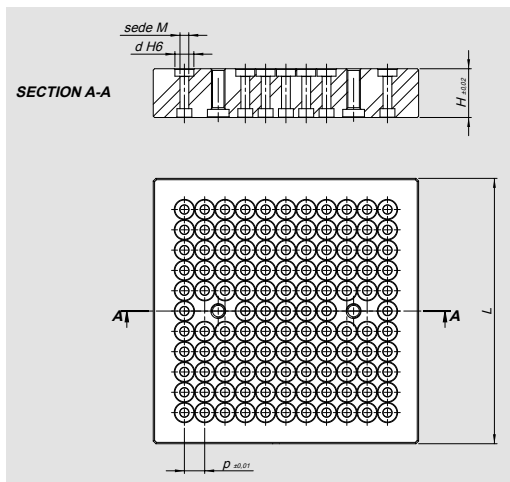

Id. No.	H	L	D	M	p
46233112	36	196	14	M6	15
46233113	36	246	14	M6	15
46233114	36	296	14	M6	15
46233121	36	246	16	M8	20
46233122	36	296	16	M8	20
46233131	46	246	18	M10	25
46233132	46	296	18	M10	25

PIN FOR MINIPALLET

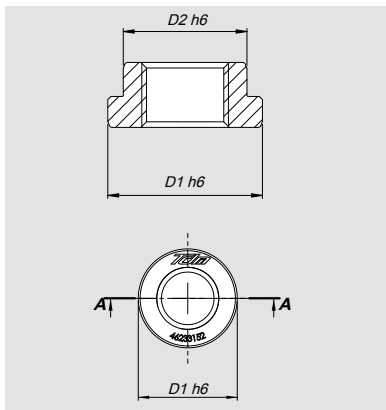

Id. No.	D1	D2	For screw
46233141	14 h6	10 h6	M6
46233142	14 h6	11 h6	M6
46233151	16 h6	12 h6	M8
46233152	16 h6	14 h6	M8
46233161	18 h6	14 h6	M10
46233162	18 h6	16 h6	M10

SPACER FOR MINIPALLET

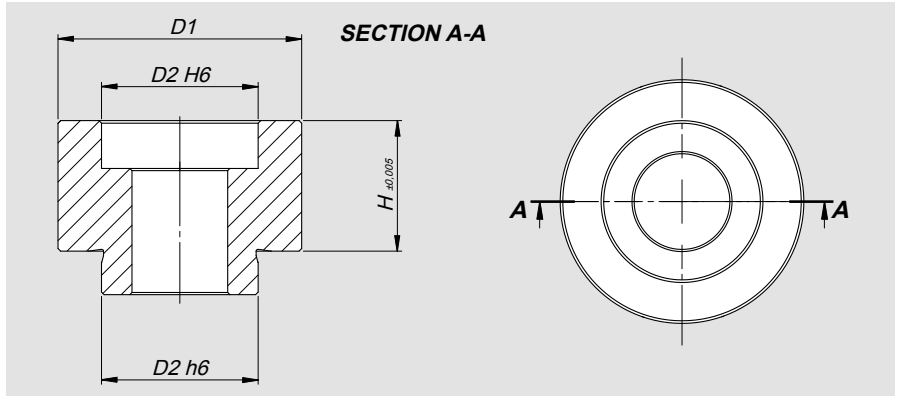

Id. No.	D1	D2	H	For screw
46233371	22	14	8	M6
46233372	22	14	12	M6
46233373	22	14	16	M6
46233381	25	16	10	M8
46233382	25	16	15	M8
46233383	25	16	20	M8
46233391	28	18	15	M10
46233392	28	18	25	M10
46233393	28	18	35	M10

Spacer and pin working example for minipallet

M6

Clamping Workpiece

46233141 (ø10)
46233142 (ø11)

46233373

46233372

46233371

46233112 (196x196)
46233113 (246x246)
46233114 (296x296)

TCEI M6 12,9

46231552 (4)

46230105 (TDM 48)

M8

Clamping Workpiece

46233151 (ø12)
46233352 (ø14)

46233383

46233382

46233381

46233121 (246x246)
46233122 (296x296)

TCEI M8 12,9

46231552 (4)

46230105 (TDM 48)

M10

Clamping Workpiece

46233161 (ø14)
46233162 (ø16)

46233393

46233392

46233391

46233131 (246x246)
46233132 (296x296)

TCEI M10 12,9

46231552 (4)

46230105 (TDM 48)

ADAPTOR BETWEEN TDM88, 48 and MINIPALLET

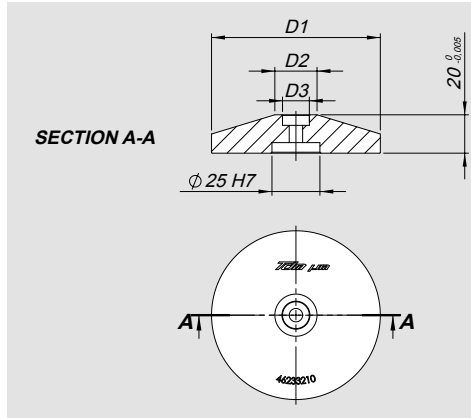

Id. No.	D1	D2	D3
46233210	88	22	14 H6
46233220	88	25	16 H6
46233230	88	28	18 H6
46233260	48	22	14 H6
46233270	48	25	16 H6
46233280	48	28	18 H6

Adaptor working example

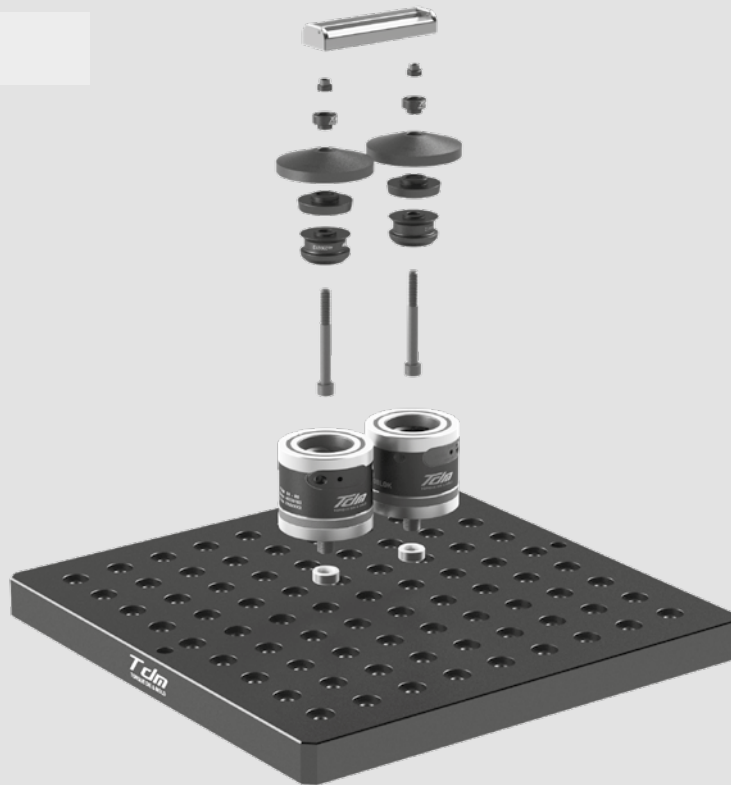

OP 10

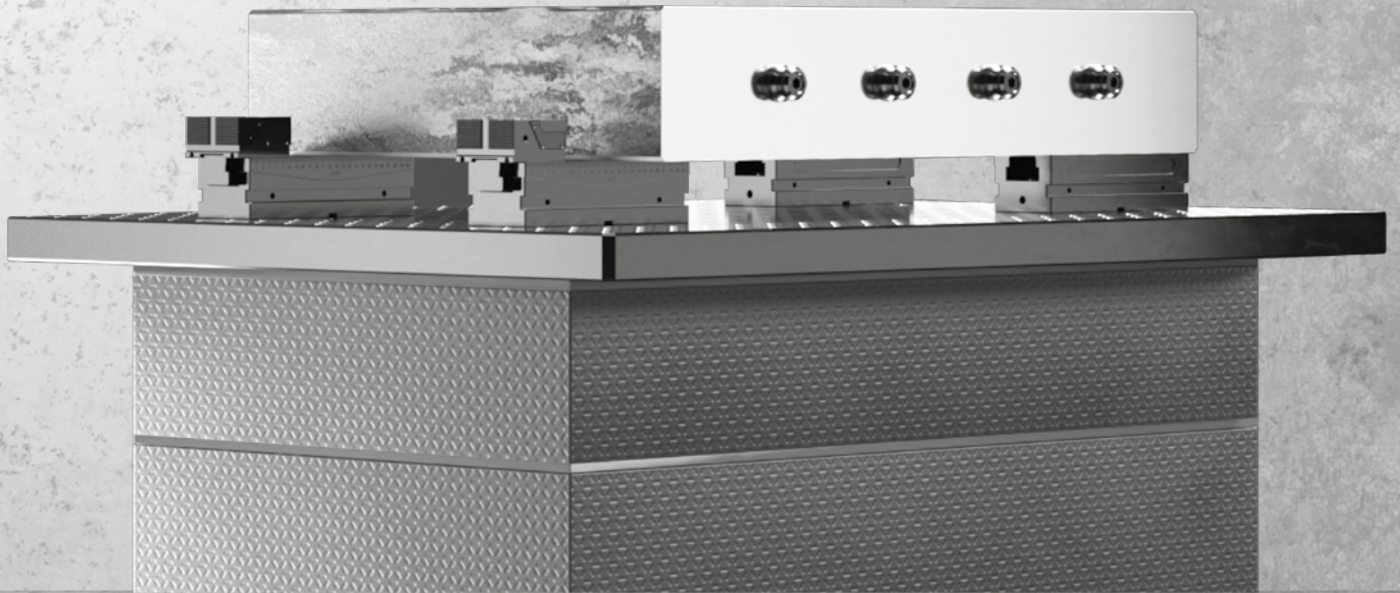

BASE CIVI 90/250



Codice - Id. No.
46233750

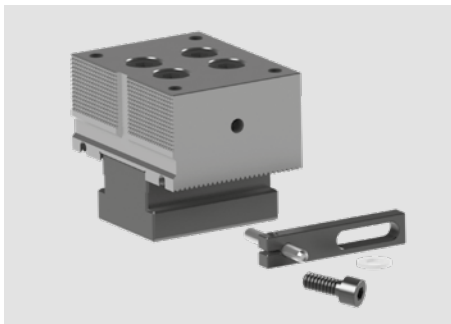
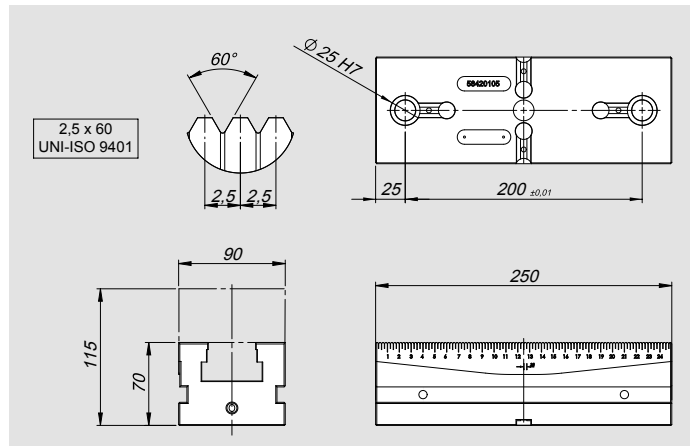

Complete fixed support
J90 grooved

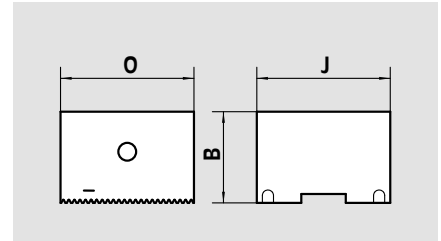

Id. No.	model	B	J	O	Weight
58427200	CIVI 2000/90	45	90	70	2,9



Fixed jaw set Sintergrip J90
complete with 1 work stop, n. 3 SinterGrip
inserts STD for steel*

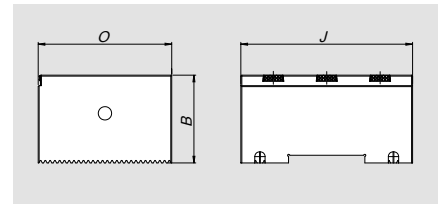

* A richiesta inserti per ALU o HRC
* On request inserts for ALU or HRC

Id. No.	model	B	J	O	Weight
58467290	CIVI 2000/90	45	90	70	2,9

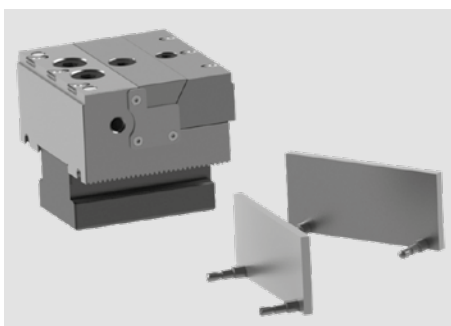

Movable jaw set J90
complete with 1 work stop, n. 6 SinterGrip
inserts STD for steel*, n. 1 pair of parallels
H42.

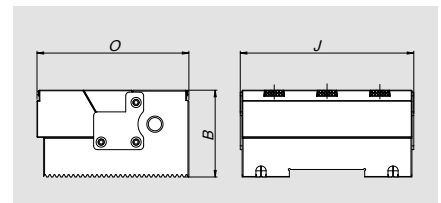

* A richiesta inserti per ALU o HRC
* On request inserts for ALU or HRC

Id. No.	model	B	J	O	Weight
77584690	CIVI 2000/90 x ...	45	90	80	2,9



Movable jaw set J90 with
grooved jaws
(for raw workpieces)

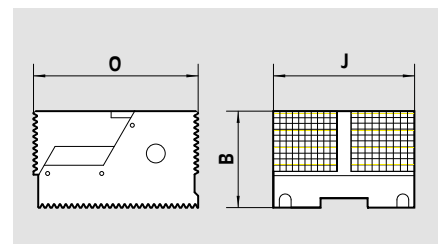

Id. No.	model	B	J	O	Weight
77584228	CIVI 2000/90	45	90	80	2,9

Working example

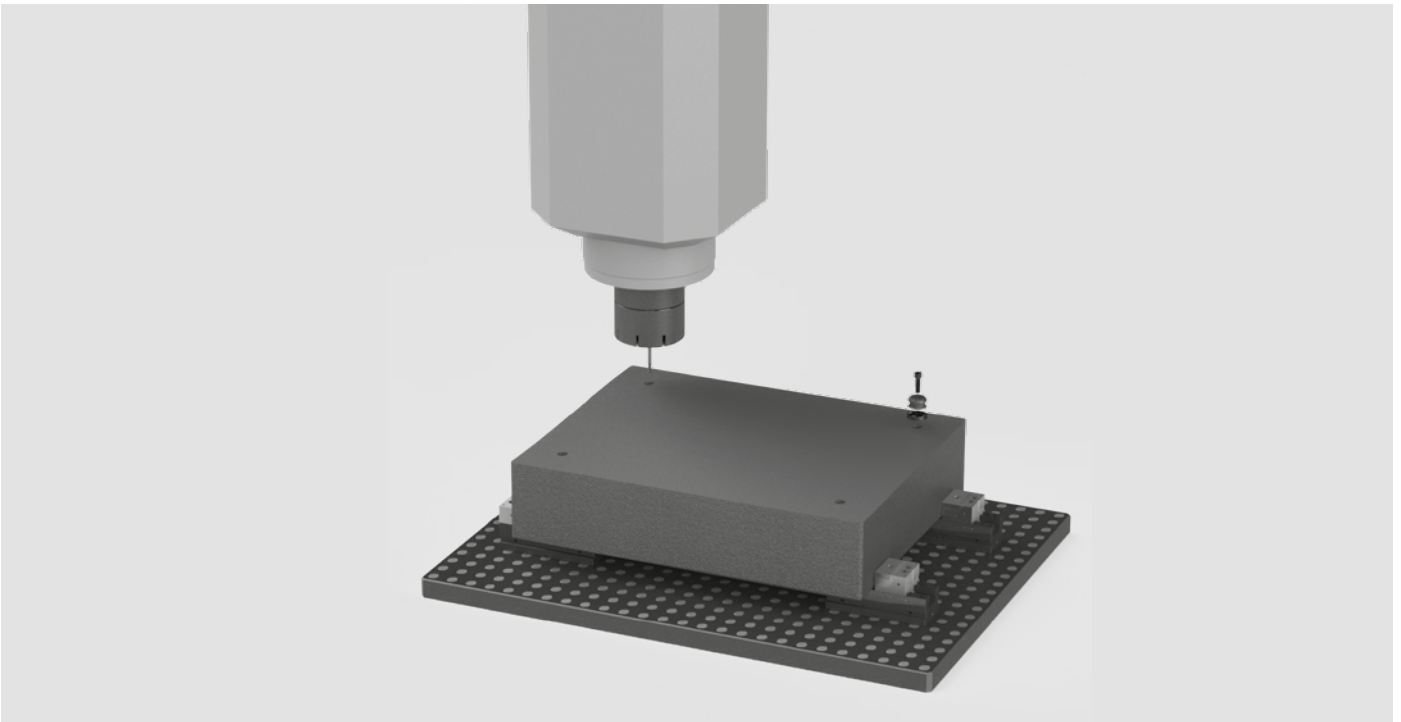

Working example with SinterGrip

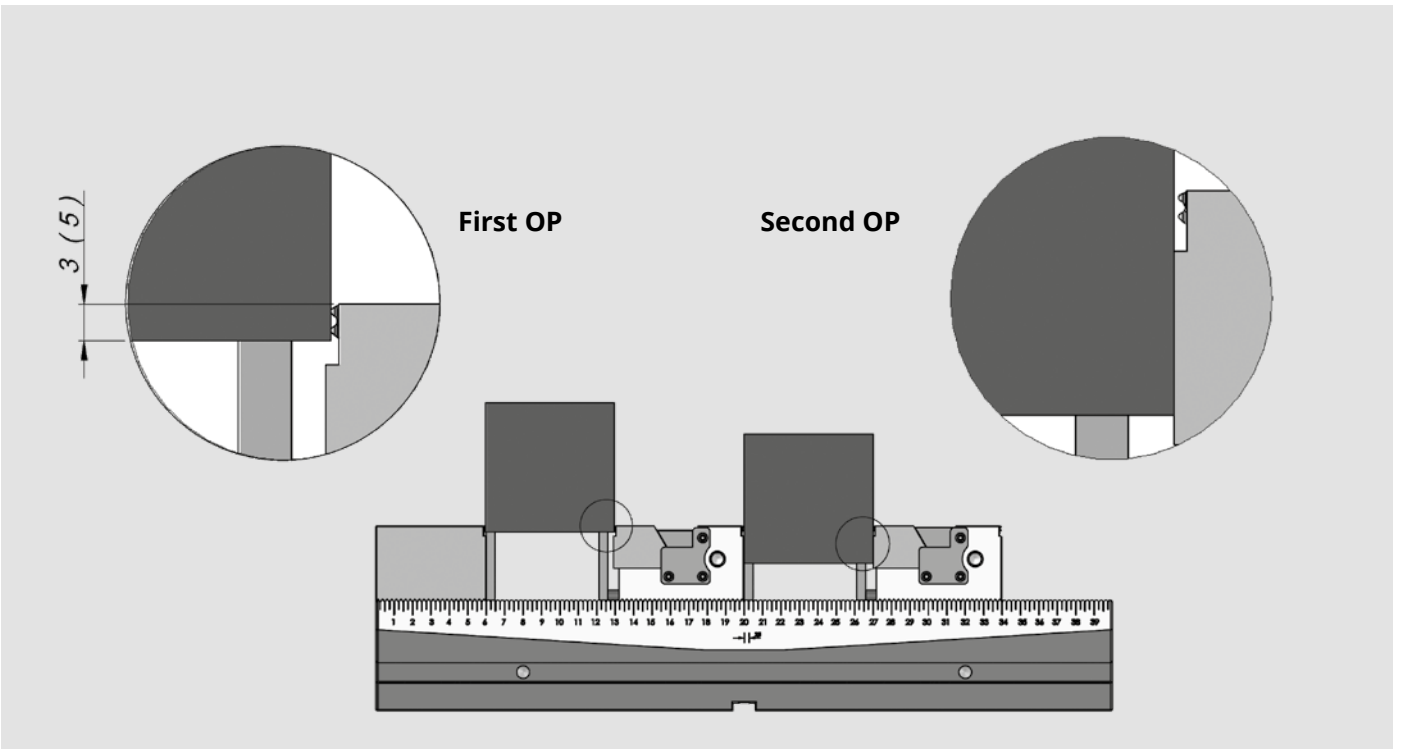

SIDE CLAMPS FOR 1ST OP.



Body	
Material	S45C steel
Finish	black oxide
Treatment	heat treated

Arm	
Material	S45C steel
Finish	black oxide

Jaw	
Material	SKH51 steel
Finish	black oxide
Treatment	heat treated

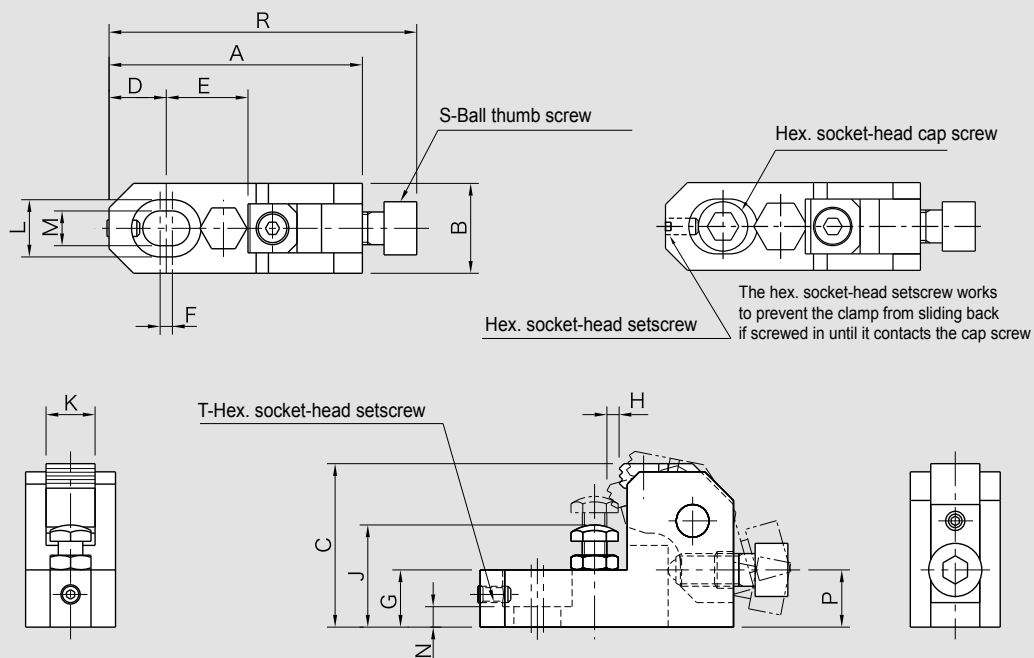

Id. No.	A	B	C	D	E	F	G	H	J	K	L	M
	mm	mm	mm	mm	mm							
51 99 15 67	93	32	60	21	30	5	21	4.5	40 a 48	20	20	13
51 99 15 68	124	38	80	28	40	6	27	6	48 a 63	25	26	17

Id. No.	N	P	R	S	T	Clamping force	Allowable screw torque	Weight
						N	N•m	Kg
51 99 15 67	8	21	113	M12x1.75-30L	M6x1-12L	17.000	65	0,75
51 99 15 68	10	28	151	M16x2-40L	M8x1.25-16L	25.000	130	1,57

TdM APS



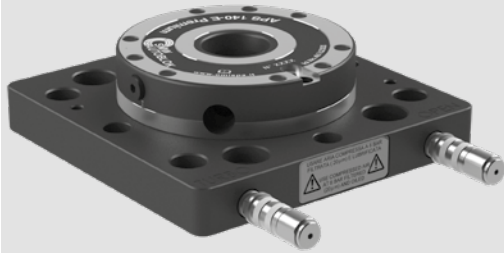

Application/Benefits

- Pre-assembled clamping unit with 1 piece APS 140 Premium
- Universal applicable
- Fast and easy set-up

Technical features

- 3 clamping slides
- Repeatability < 0.005 mm
- Turbo function to increase the pull-in forces (pull-in force without Turbo 7.5 kN)
- Anti rotating protection
- Air cleaning

Standard equipment

Clamping unit with 1 piece APS 140 Premium

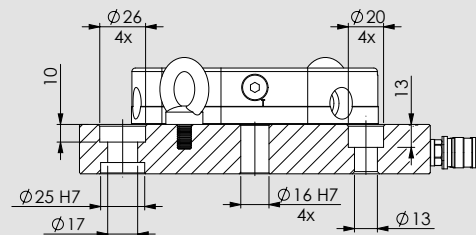
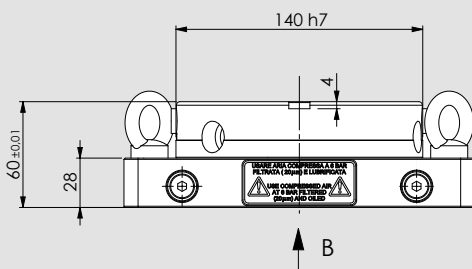

SECTION C-C

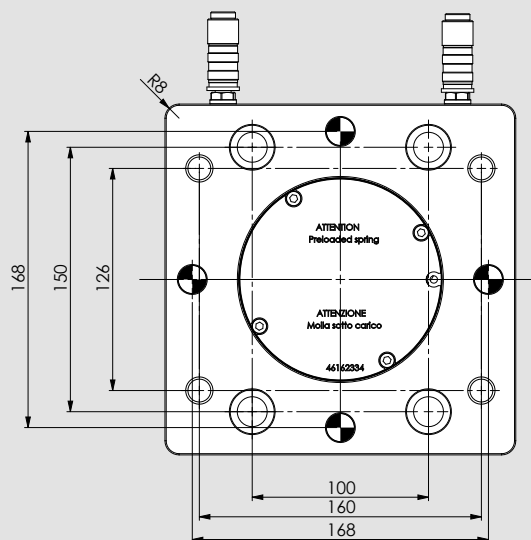
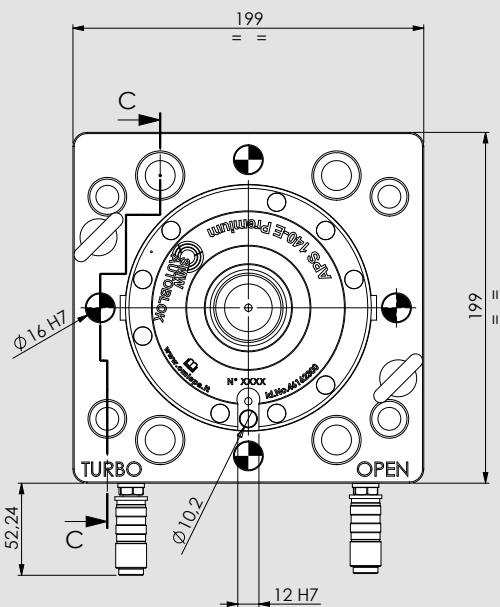

VIEW B

Type	Id. No.	Heigh mm	Weight kg
Module extention with 1 APS 140 Premium	46168410	60	11



Application/Benefits

- Pre-assembled clamping unit with 2 pieces APS 140 Premium Light or Basic
- Universal applicable
- Fast and easy set-up

Technical features

- 3 clamping slides (Basic: 2 clamping slides)
- Repeatability < 0.005 mm
- Turbo function for increasing the pull-in forces (pull-in force without Turbo 7.5 kN)
- Air cleaning (only Premium Light)
- Grid dimension 200 mm

Standard equipment

Clamping unit with 2 pieces APS 140 Premium Light or Basic
Quick pneumatic connections

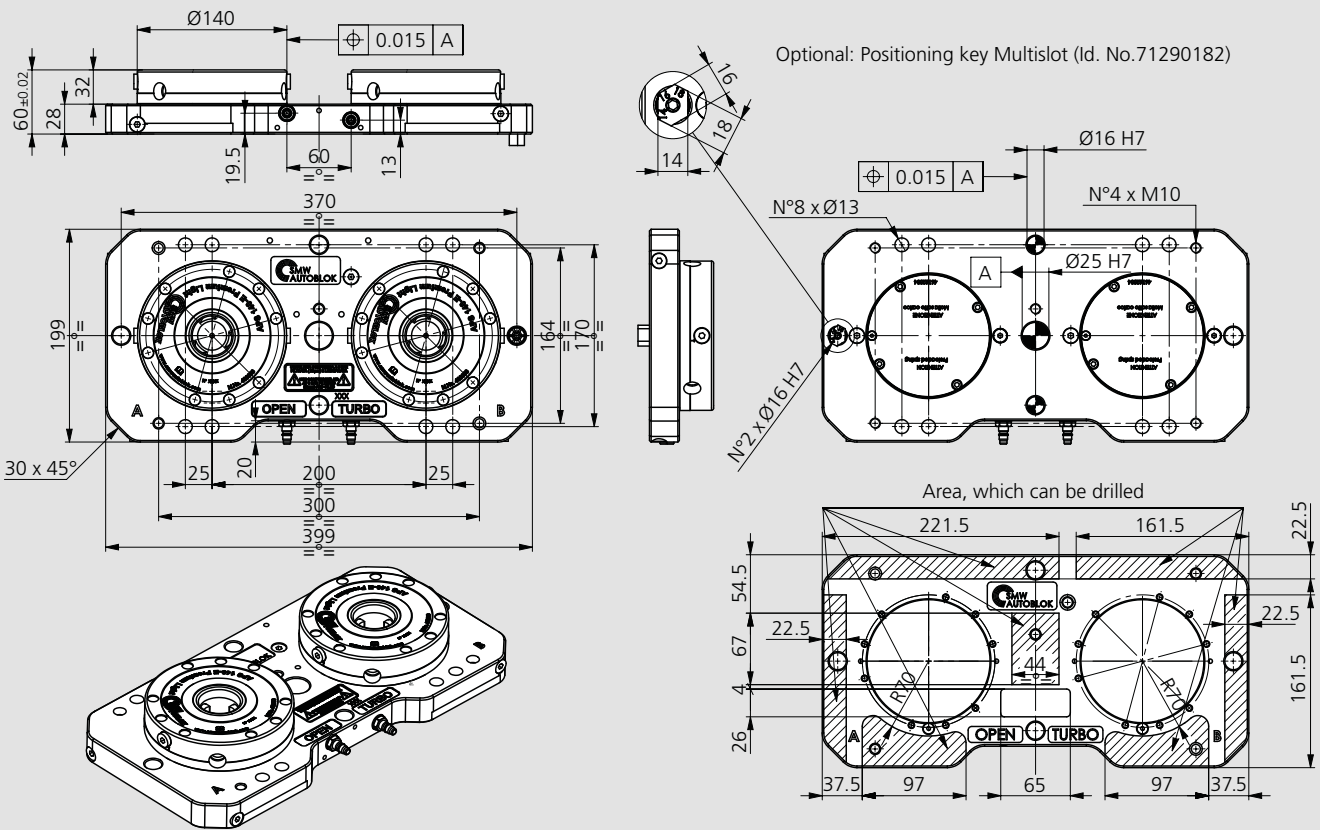

Type	Id. No.	Pull-in force with Turbo kN	Repeatability mm	Weight kg
Clamping unit with 2 APS 140-E Premium Light	460020	26*	< 0.005	21
Clamping unit with 2 APS 140-E Basic	460021	26*	< 0.005	21

* For each module.



Application/Benefits

- Pre-assembled clamping unit with 4 pieces APS 140 Premium Light or Basic
- For 5-axis machining center
- Universal applicable
- Fast and easy set-up

Technical features

- 3 clamping slides (Basic: 2 clamping slides)
- Repeatability < 0.005 mm
- Turbo function to increase the pull-in forces (pull-in force without Turbo 7.5 kN)
- Air cleaning (only Premium Light)

Standard equipment

Clamping unit with 4 pieces APS 140 Premium Light or Basic
Quick pneumatic connections

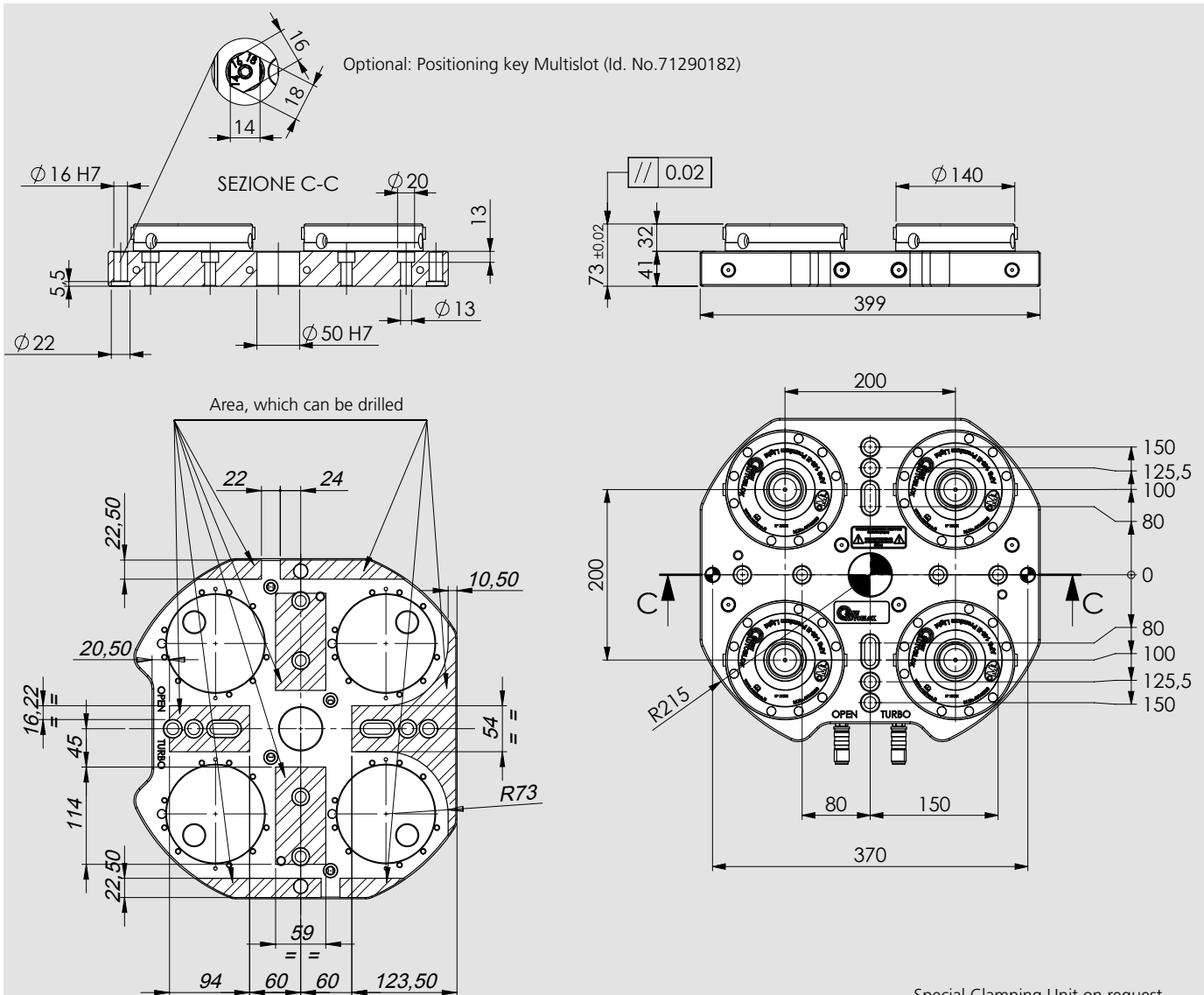

Type	Id. No.	Pull-in force with Turbo kN	Repeatability mm	Weight kg
Clamping unit with 4 APS 140 Premium Light	46168020	26*	< 0.005	45
Clamping unit with 4 APS 140 Basic	46168025	26*	< 0.005	45

* For each module.

INTERFACE FLANGE TDM 48-88 - APS 140/160 complete with screws (not single use)

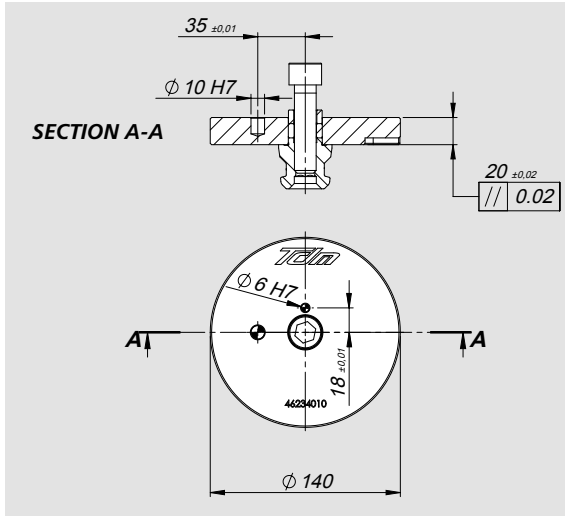
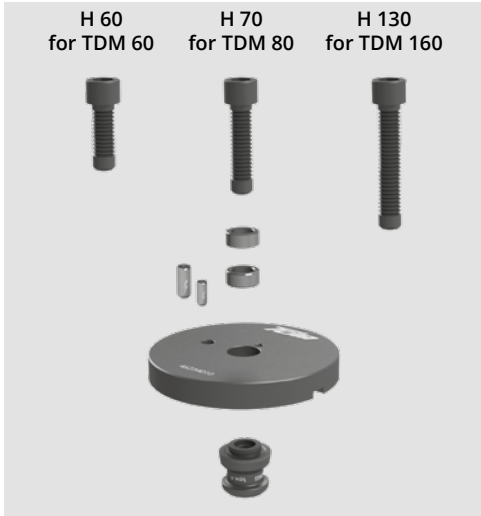

Type	Id. No.
APS140	46234010
APS160	46234020

INTERFACE FLANGE TDM88 - APS 190 complete with screws

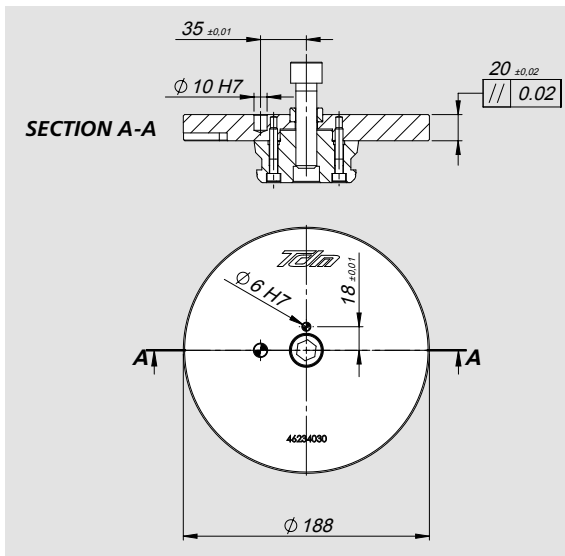

Id. No.
46234030

Working examples

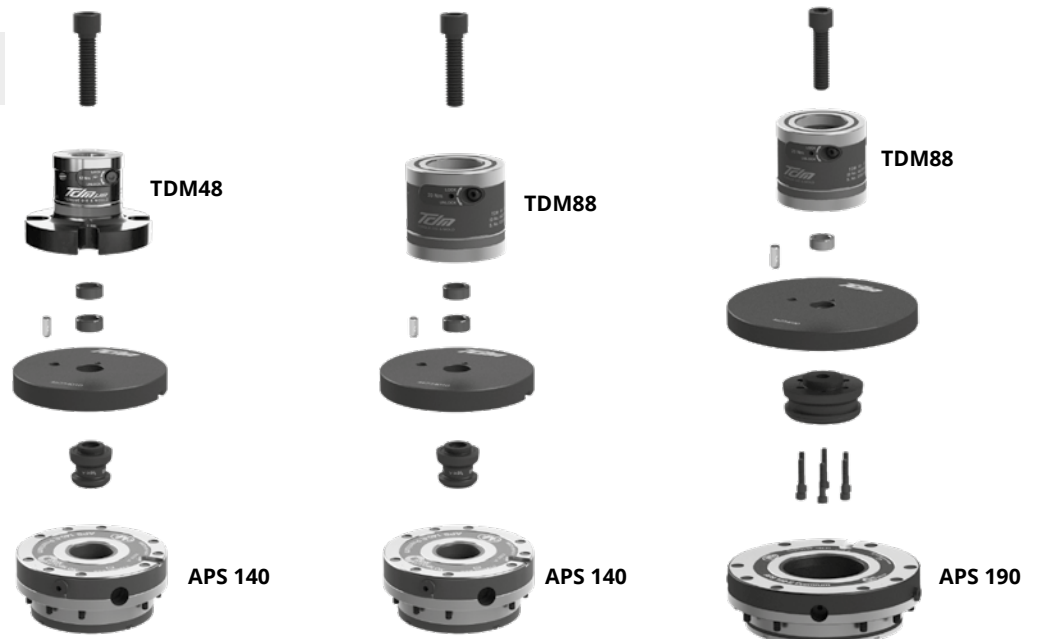

Working examples

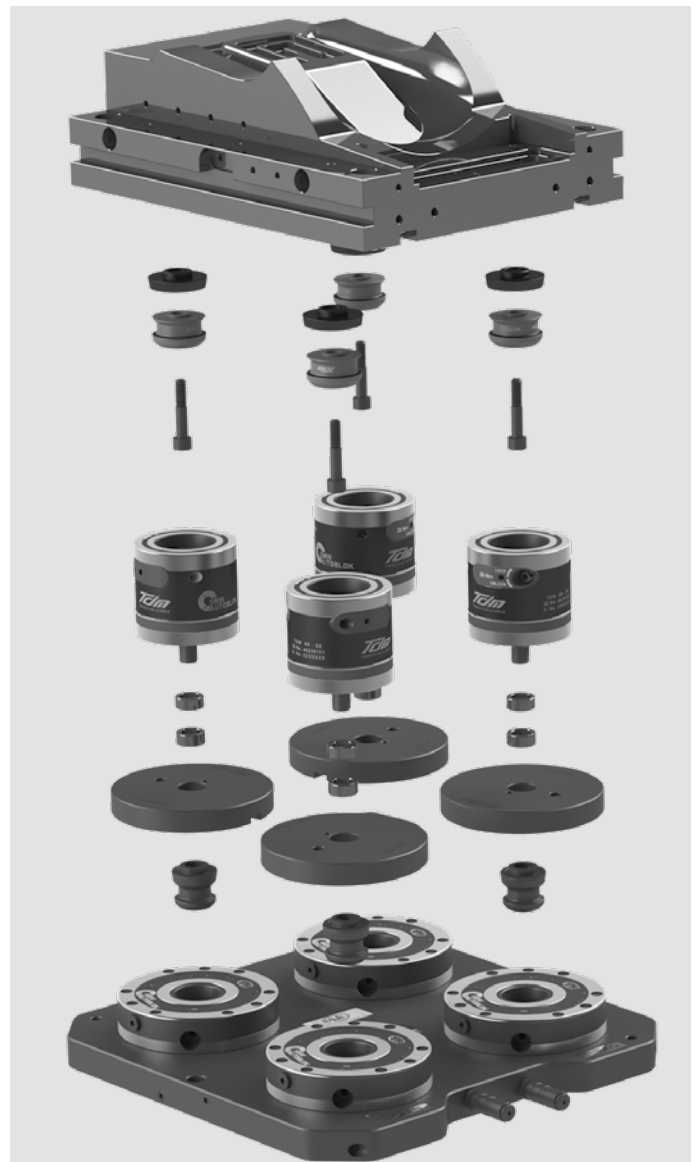

Positions of the clamping pins

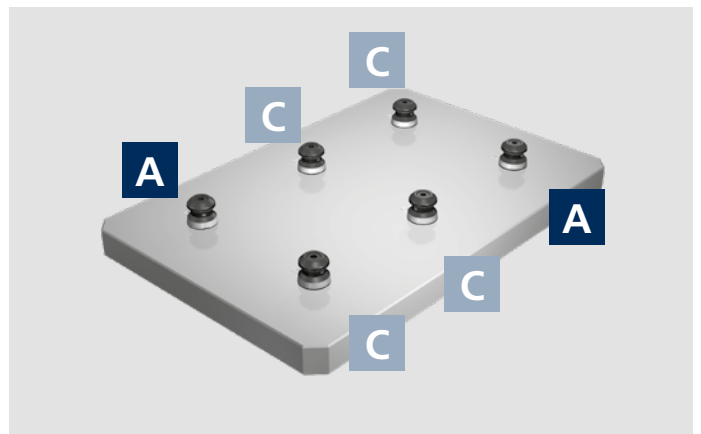
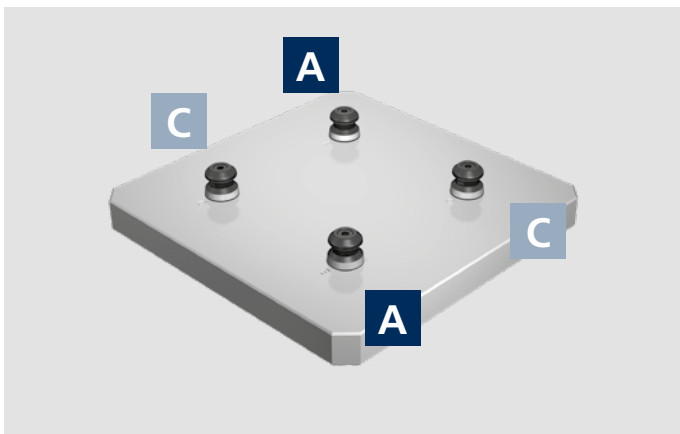
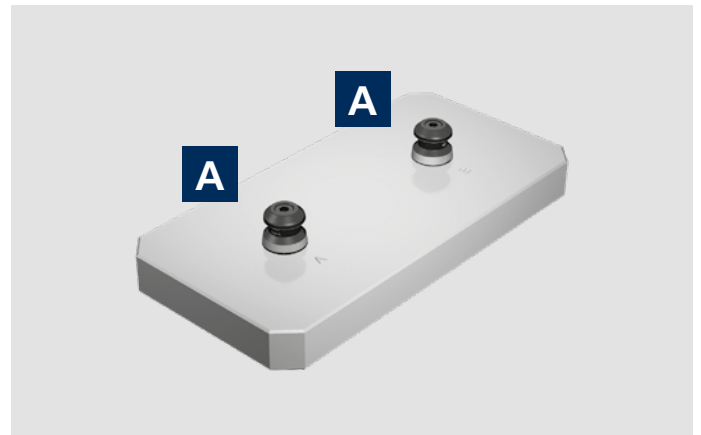

Posizionamento perni flottanti - Positions of the floating pins

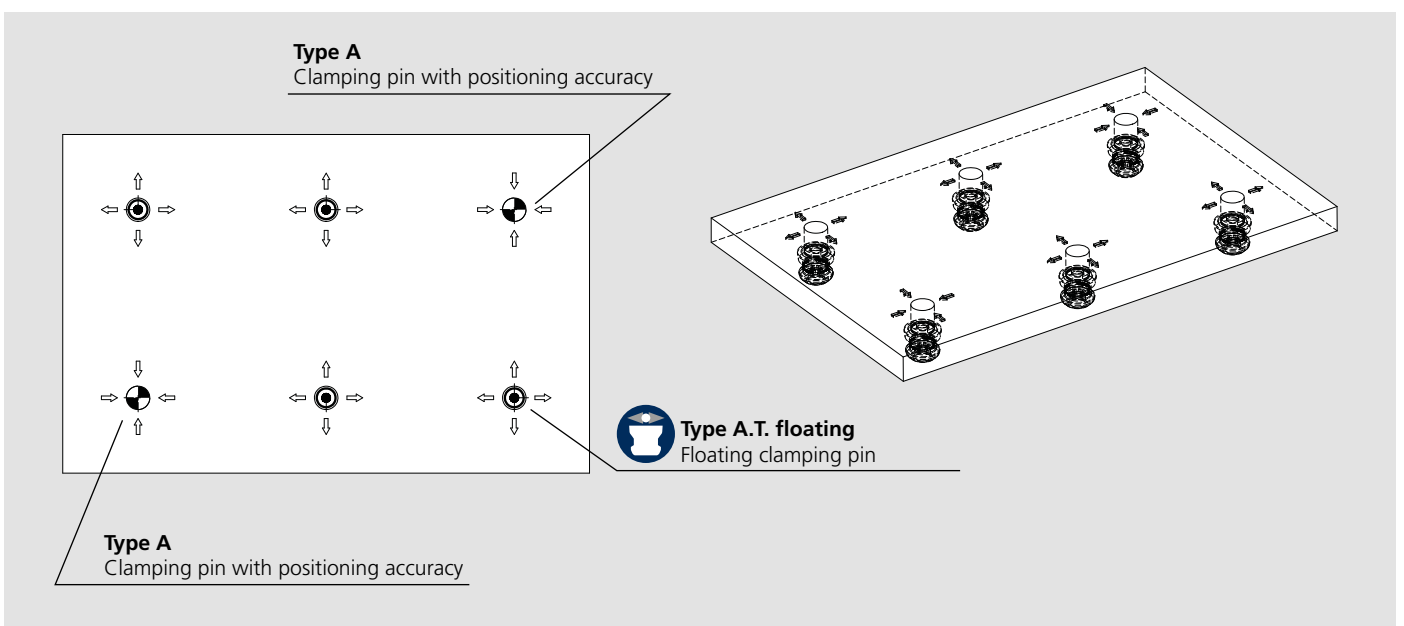

ISO METRIC PITCH

	Screw 12.9	Hex Wrench	Resistant Section rated mm ²	Max torque Nm
TDM 88	M12 x 1.75	10	84,3	120
TDM 88	M16 x 2	14	157	300
TDM 48	M6	3	20,1	14
TDM 48	M8	4	36,6	34
TDM 48	M10	5	58	70

MAXIMUM USAGE LIMIT

Screw 12.9		Maximum Usage Limit		
Thread on steel with Rm ≥ 950 N/mm ²		Until to Ft Admissible lateral force	Until to Fr Admissible holding force	Until to Fd Admissible loading force
TDM 88	M12 x 1.75	30 kN	50 kN	100 kN
TDM 88	M16 x 2	30 kN	100 kN	100 kN
TDM 48	M6	10 kN	12 kN	75 kN
TDM 48	M8	10 kN	22 kN	75 kN
TDM 48	M10	10 kN	35 kN	75 kN

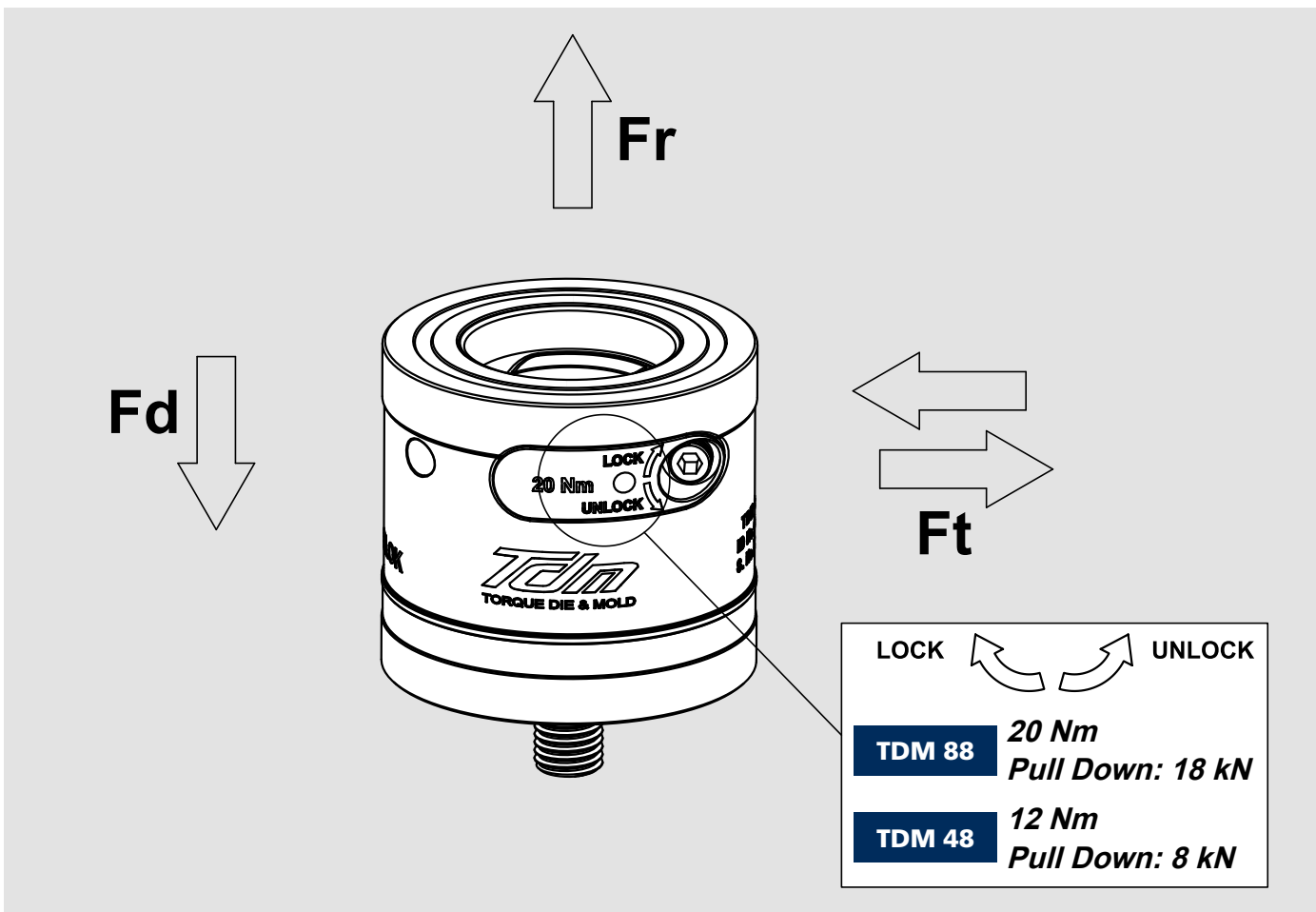

WORKPIECE PREPARATION

Screw	Ø	A	B Steel	B Cast Iron / Alloy
M6*	10-11 mm H6	5,5	16 mm	20 mm
M6	10-11 mm H6	5	16 mm	20 mm
M8*	12-14 mm H6	5,5	20 mm	27 mm
M8	12-14 mm H6	5	20 mm	27 mm
M10*	14-16 mm H6	5,5	22 mm	29 mm
M10	14-16 mm H6	6	22 mm	29 mm
M12	18-20 mm H6	6	26 mm	32 mm
M16	22-24 mm H6	6	32 mm	40 mm

* For TDM 48 range

