

SINTERGRIP

S

The New Choice



The advantages of the system

SinterGrip: the new choice

Page S.2

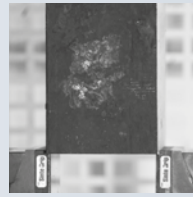

Jaws

All in one, Standard, Starter Kit

Pag. S.12

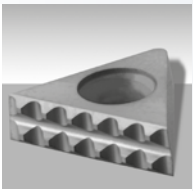

Technical features

Pag. S.4



Products

All in one, Standard, Starter Kit

Pag. S.14

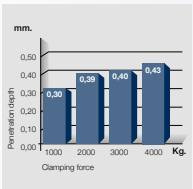

Charts

Penetration depth / clamping force

Pag. S.8



Accessories

Pag. S.18



Clak System

Quick change system

Pag. S.10



Clak

Modular parallels

Pag. S.19

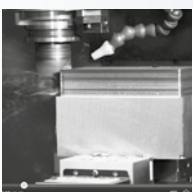

Application examples

Milling on horizontal machining centre, vertical machining centre and 5 axis

Pag. S.11

SinterGrip

Clamping Insert

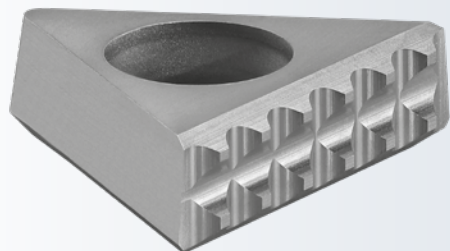

SinterGrip
Clamping Insert

WATCH THE VIDEO

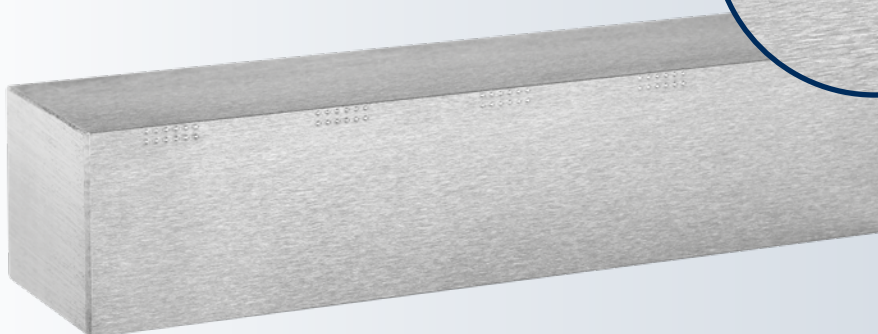

Marks on the
Workpiece

Comparison Clamping Depths

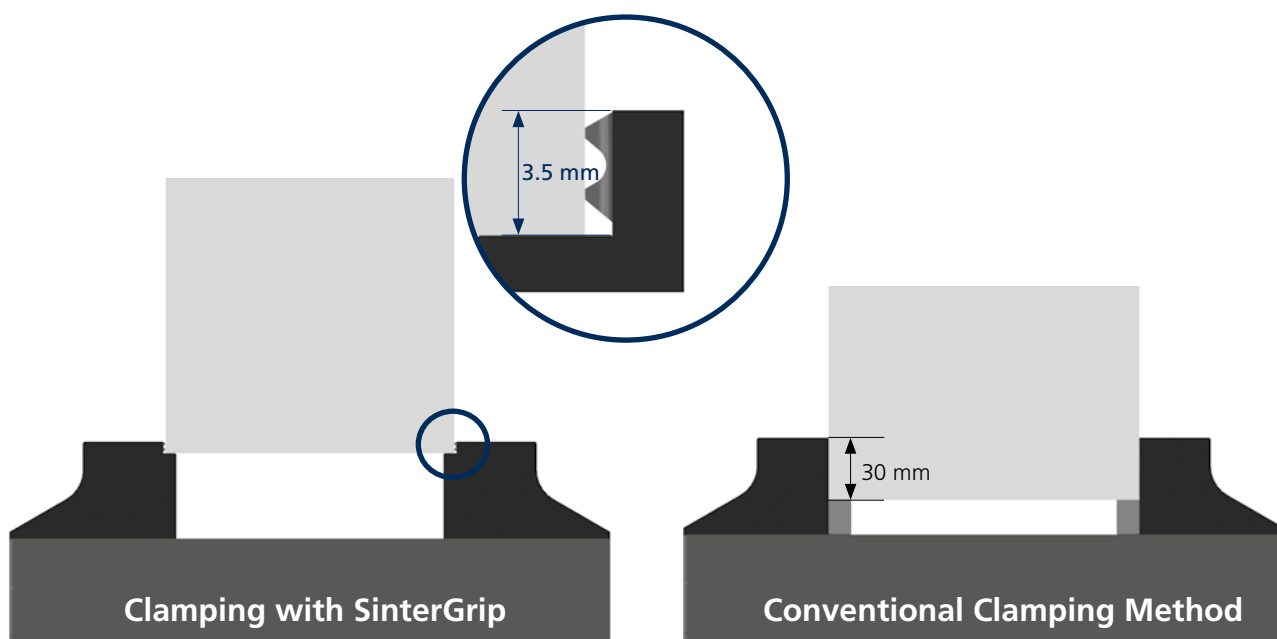

>> Lowest clamping depth of workpieces – no pre-marking

Benefits

1

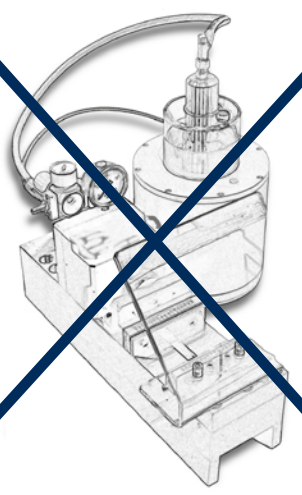

No pre-marking necessary

- Elimination of the costs for a pre-mark machine and set-up times

2

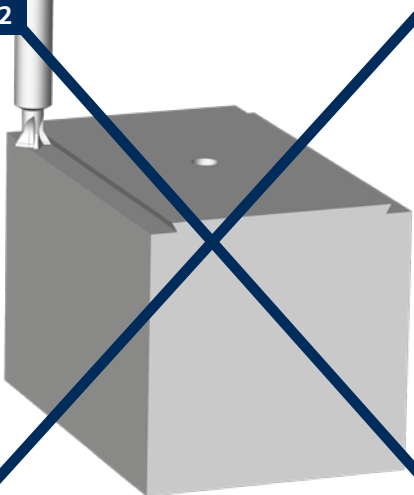





No dove tail pre-machining of the workpiece necessary

- Elimination of the costs for the pre-machining

3

4 different versions for all materials:

	
Steel	Polymers
	
Aluminium	Hardened Steel or Titanium (until 54 HRC)

4



Best accessibility and highest holding forces

- Safe clamping of workpieces
- Ideal for 5-axis machining
- High material saving due to lowest clamping depth only 3.5 mm

5

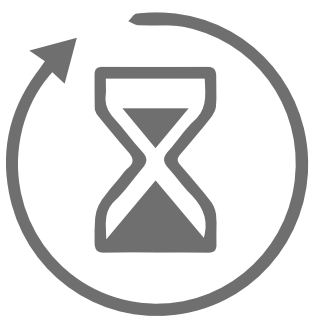

**Maximum lifetime | No wear costs
Huge metal removal rate = less time to machine the workpiece**

- SinterGrip clamping inserts are made from coated carbide steel and have maximum lifetime

6

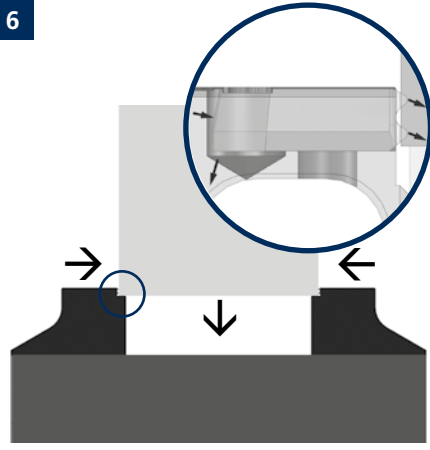

Pull-down effect | Active vibration absorption

- Even distribution of the clamping forces and active vibration absorption
- Geometric couplings without any clearance

SinterGrip are solid carbide serrated inserts type ISO P30:P35 and coated with method PVD

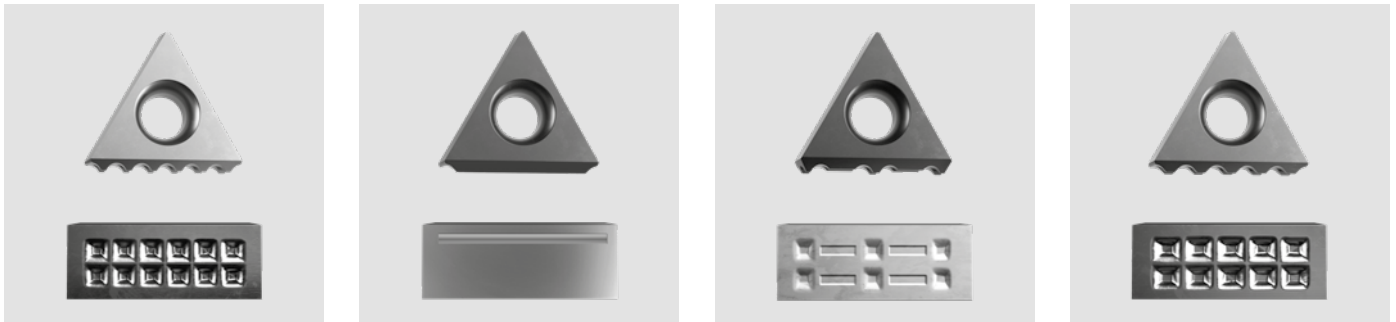

Coated cemented carbide currently represents 80-90% of all cutting tool inserts. Its success as a tool material is due to its unique combination of wear resistance and toughness, and its ability to be formed in complex shapes.

Coated cemented carbide combines cemented carbide with a coating. Together they form a grade which is customized for its application.

The big advantage of **SinterGrip** is therefore the combination of this material together with its own teeth sharpening, the special tapered shape and the special triangular shape, coming from detailed studies by our technical department.

In a general sense, the insert with its own special section of pyramid shape and special teeth sharpening penetrates into the material of the workpiece and creates some coupling without any clearance, unloading the forces and the vibrations, becoming a sole body with the vise and the workpiece.

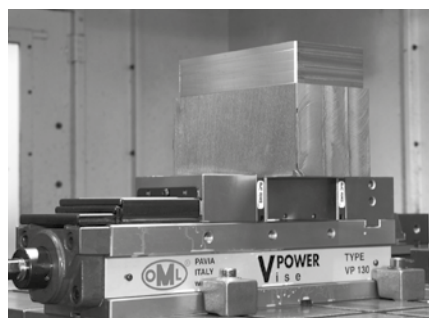

- 1 The special triangular shape creates a coupling without any clearance, in fact:
 - It divides the clamping forces;
 - It allows high coupling precision between the gripper (insert) and the jaw of the vise;
 - It absorbs the vibrations, allowing high stability.
- 2 The special tapered shape (5 degrees) of the inserts section: creates pull-down effect into the insert which is transferred to the workpiece, avoiding the lifting of the same.
- 3 The special teeth sharpening:
 - The lower angle is bigger than the upper one. This creates a pull-down effect on the workpiece;
 - Permits, after the engraving, to clamp the workpiece with a lower clamping force, avoiding any deformation of the same.

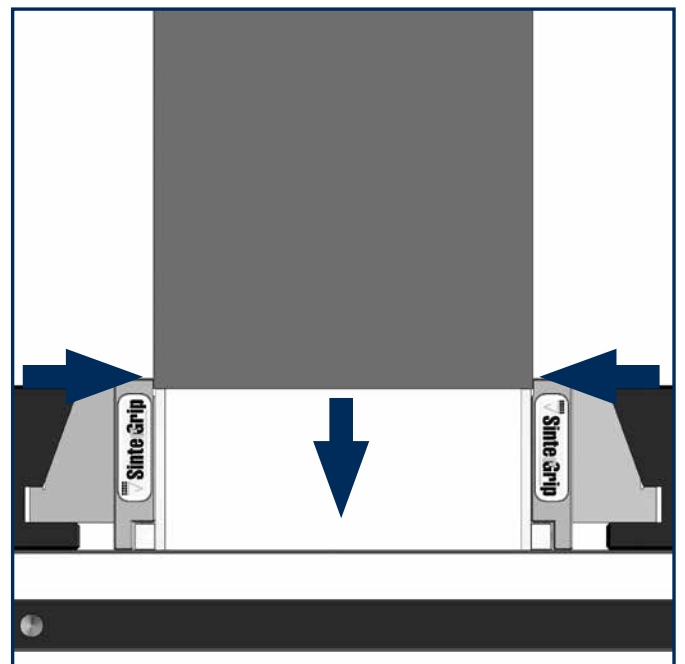
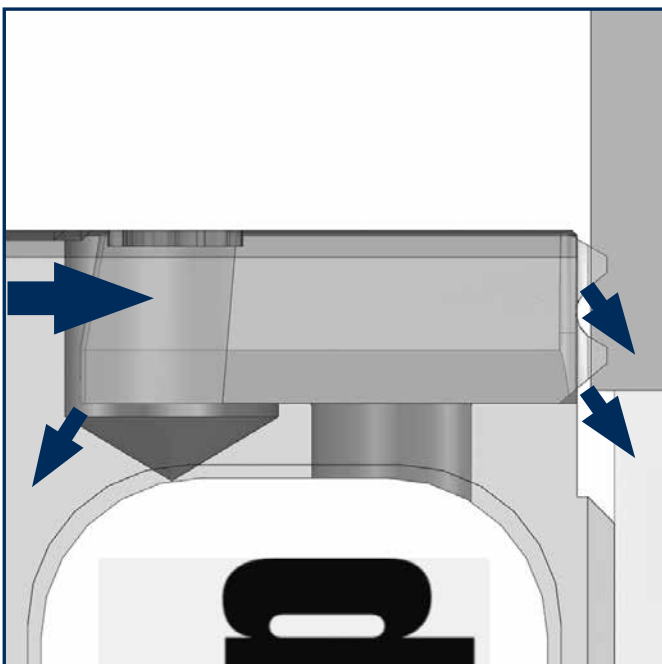
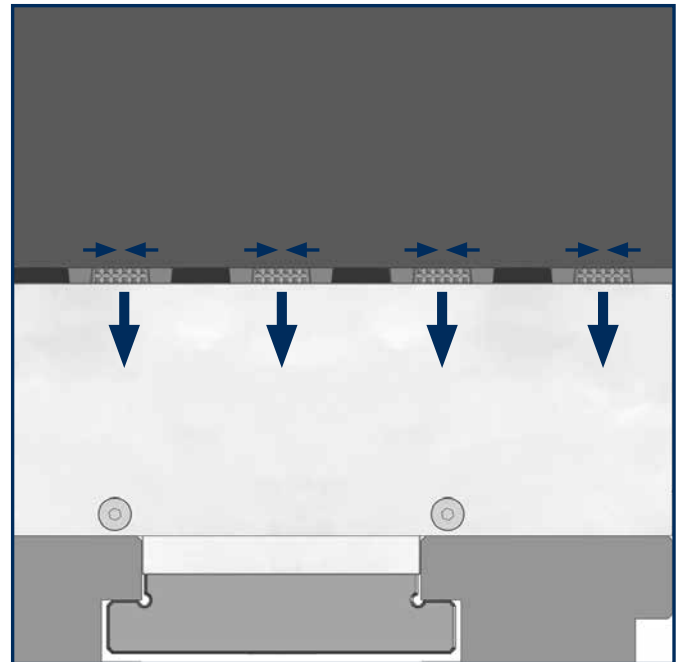
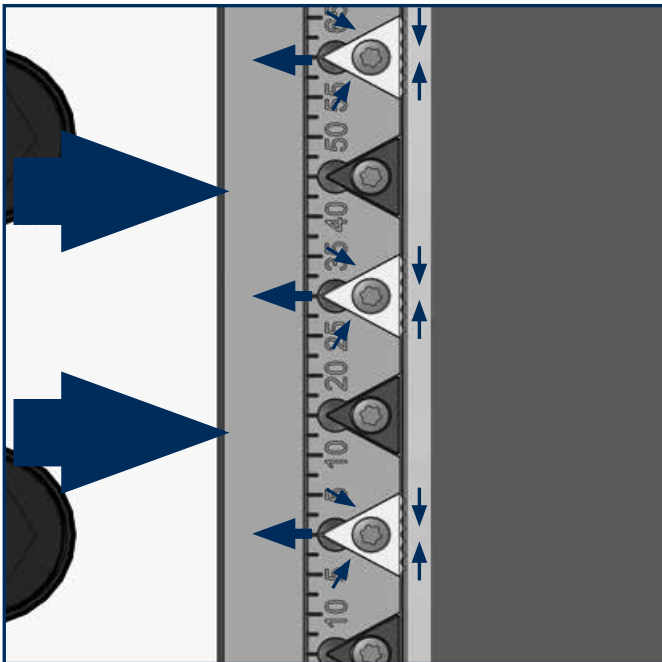

The combination of both elements (the tapered shape and the teeth sharpening) creates a double **pull-down** effect.

The New Choice



SinterGrip insert for steel (STD)

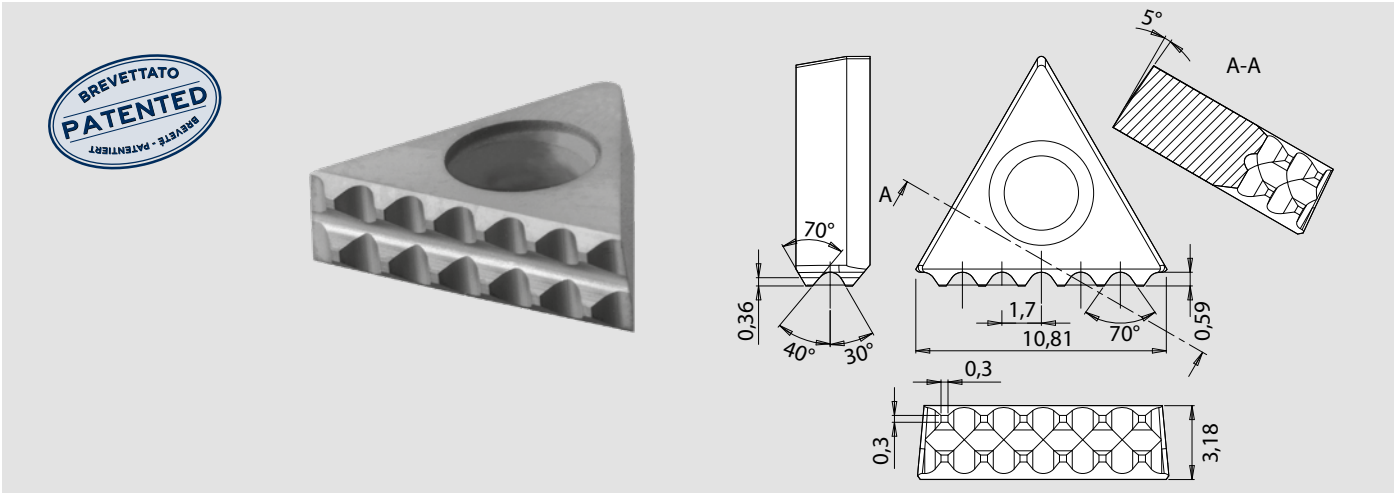

SinterGrip insert for hard steel / titanium (until 50-54 HRC)

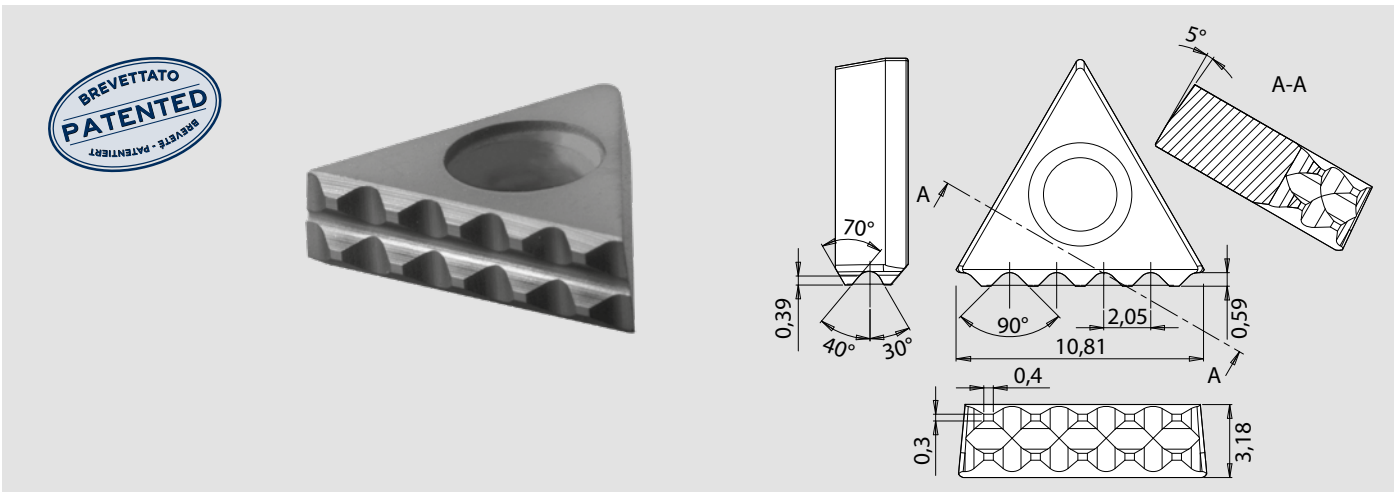

SinterGrip insert for polymeric materials

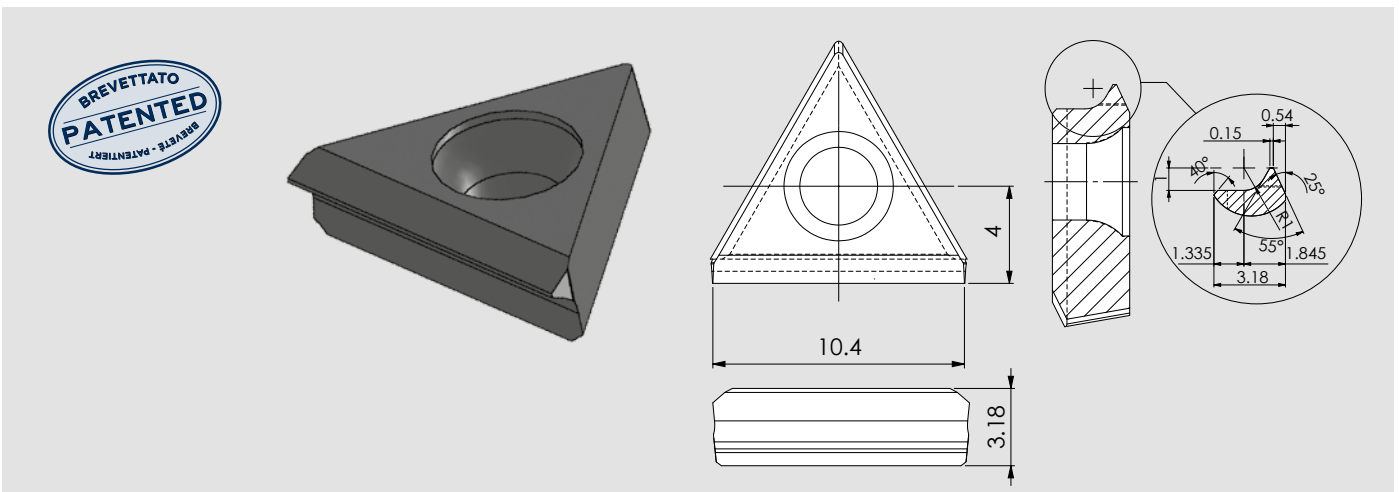



SinterGrip insert for aluminium (ALU)

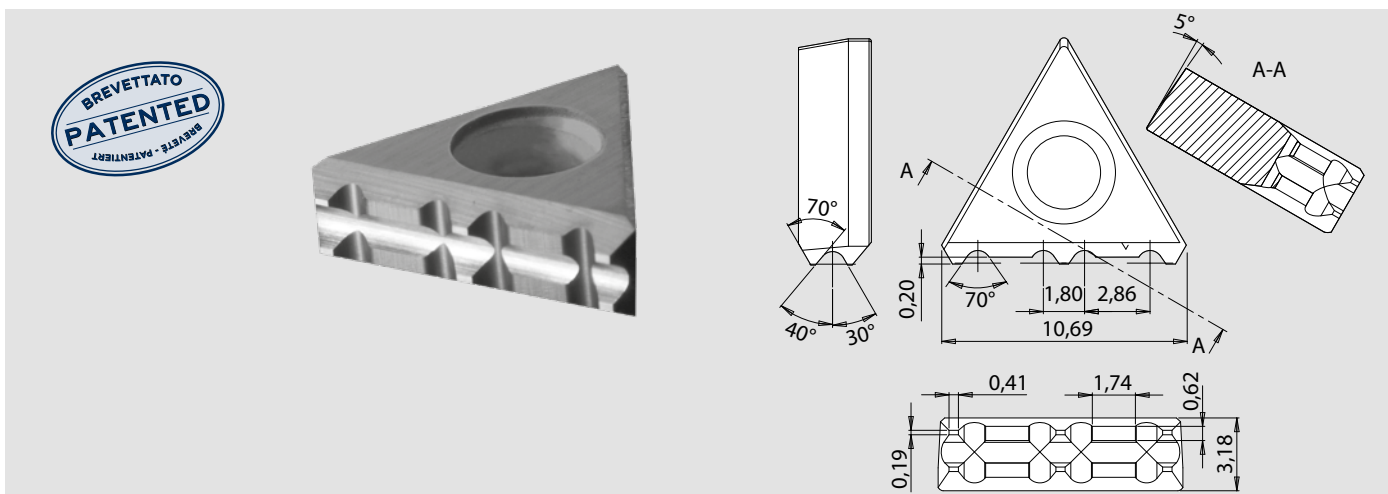

Engraving in aluminium

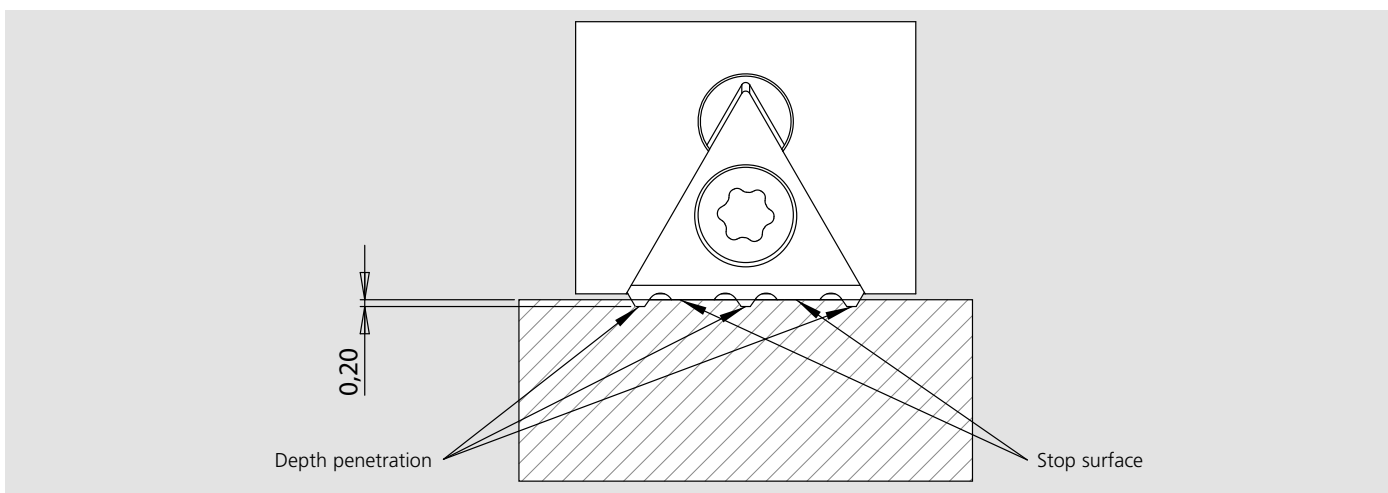

The values indicated in the chart are those of the penetration of each tooth of the insert, in relation to the number of inserts used, the type of material and the clamping force.

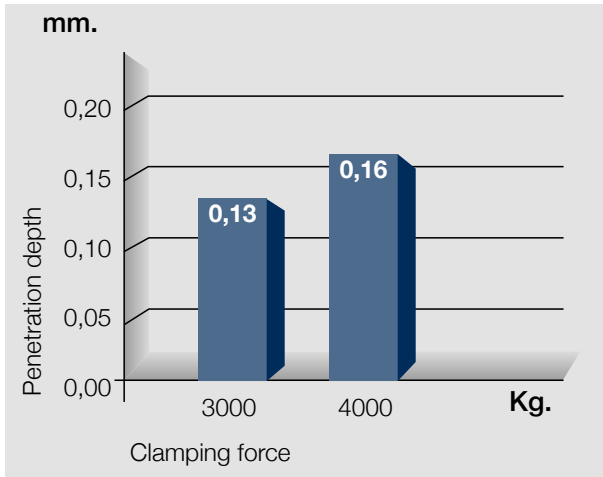

Steel with tensile strength $\approx 980 \text{ N/mm}^2$
n. 5 inserts for jaw
10 inserts total
clamping surface 3,5 mm

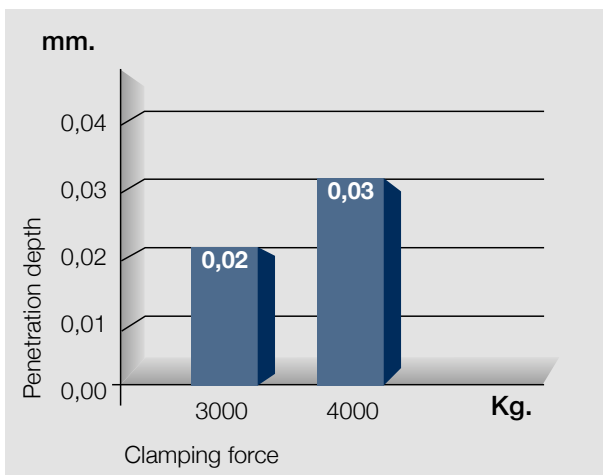

Hardened steel HRC 50-54
n. 5 inserts for jaw
10 inserts total
clamping surface 3,5 mm

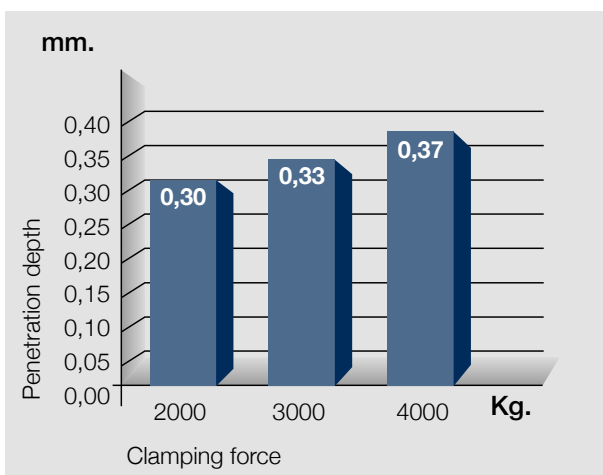

Alluminium
n. 5 inserts for jaw
10 inserts total
clamping surface 3,5 mm

The ratio between inserts and penetration depth is inversely proportional, that is, fewer inserts = more penetration

Steel with tensile strength $\approx 980 \text{ N/mm}^2$
 n. 1 inserts for jaw
 2 inserts total
 clamping surface 3,5 mm

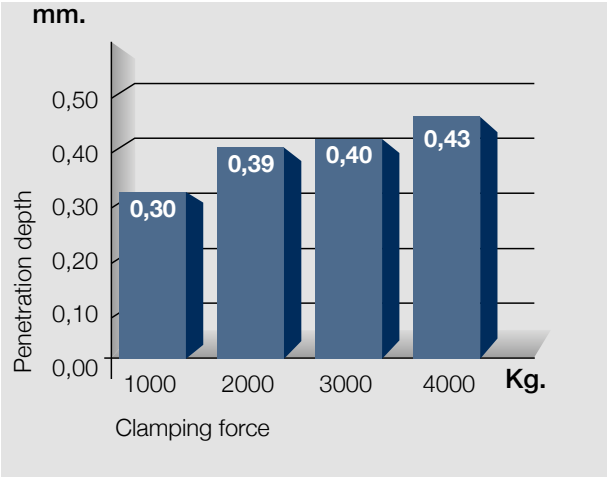

The same proportion is comparable to the clamping surface for only 2 mm, that is with one row of teeth per insert (see chart).

Steel with tensile strength $\approx 980 \text{ N/mm}^2$
 n. 5 inserts for jaw
 10 inserts total
 clamping surface 2 mm

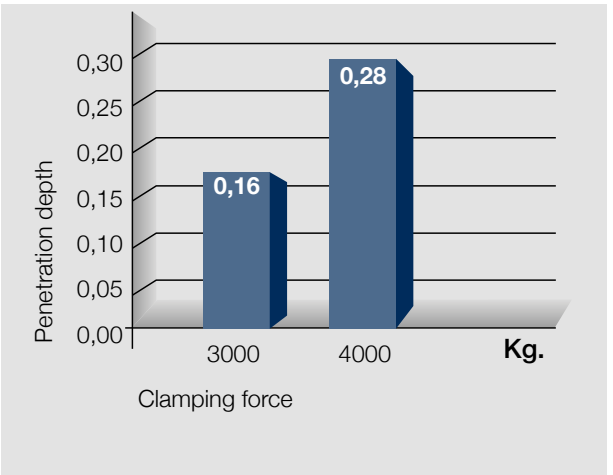

Example
 Steel with tensile strength $\approx 980 \text{ N/mm}^2$
 n. 5 inserts for jaw
 10 inserts total
 clamping surface 3,5 mm

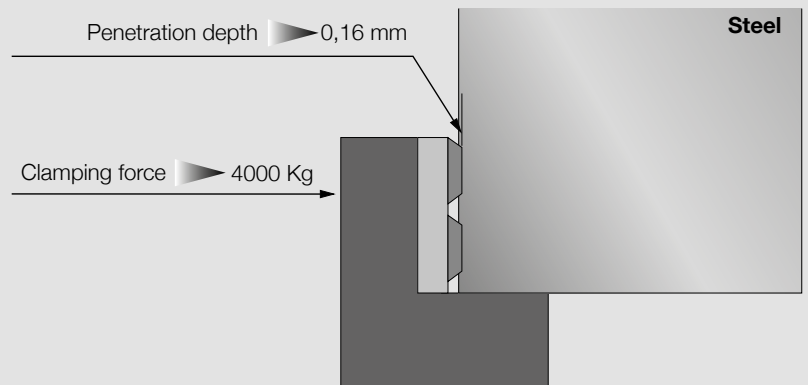

The SinterGrip method is proposed together with our unique quick change **CLAK System** for a perfect combination of performances.

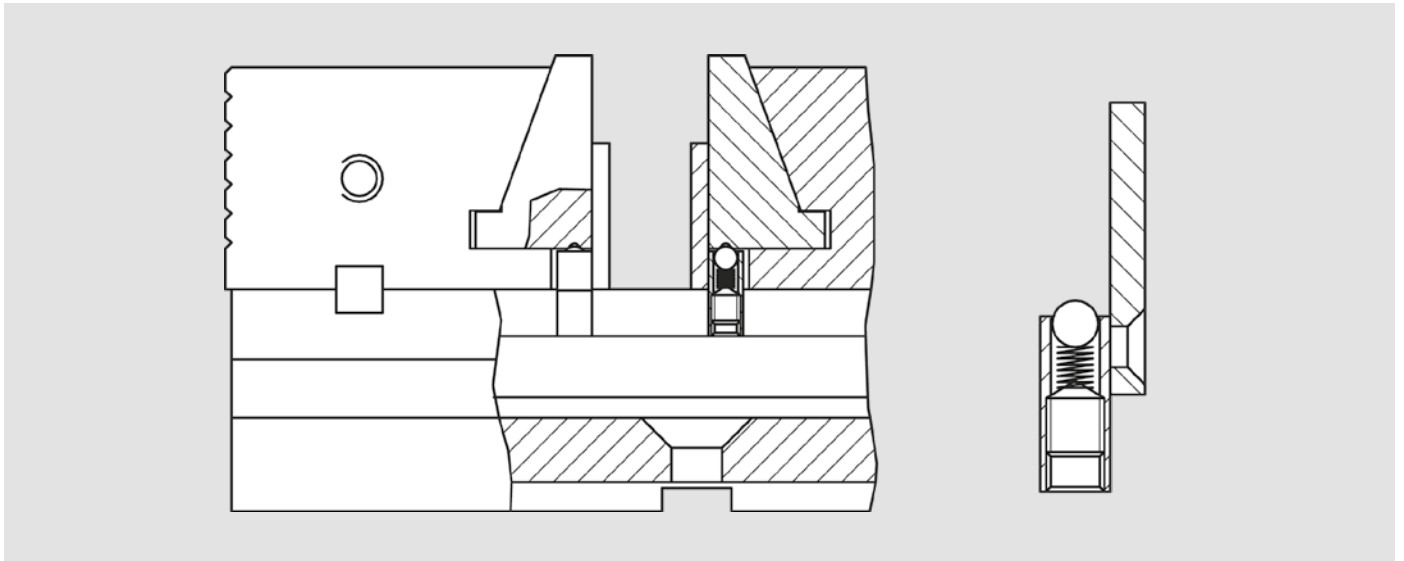

CLAK System for OML vise

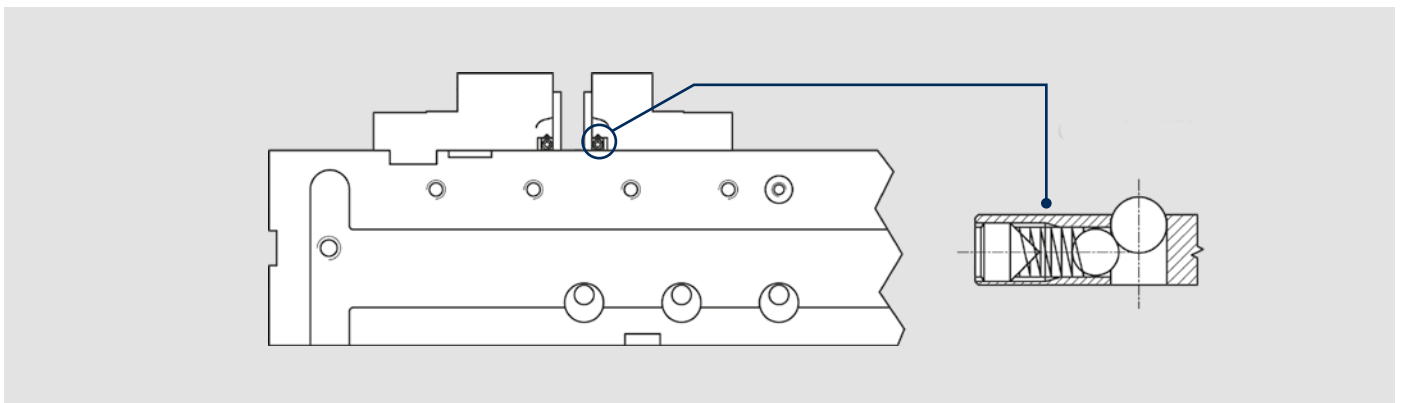
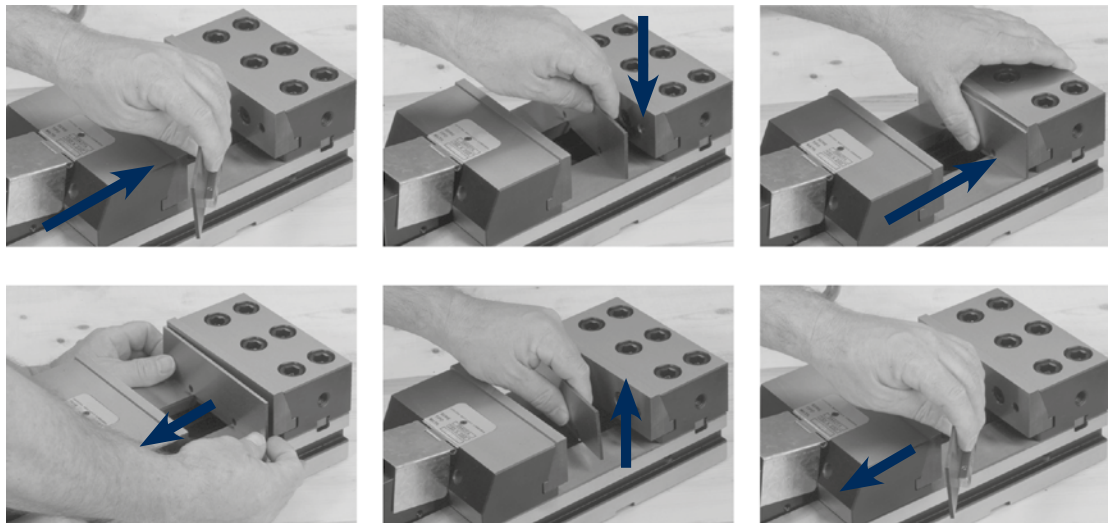

Universal CLAK System



Milling on horizontal machining centre

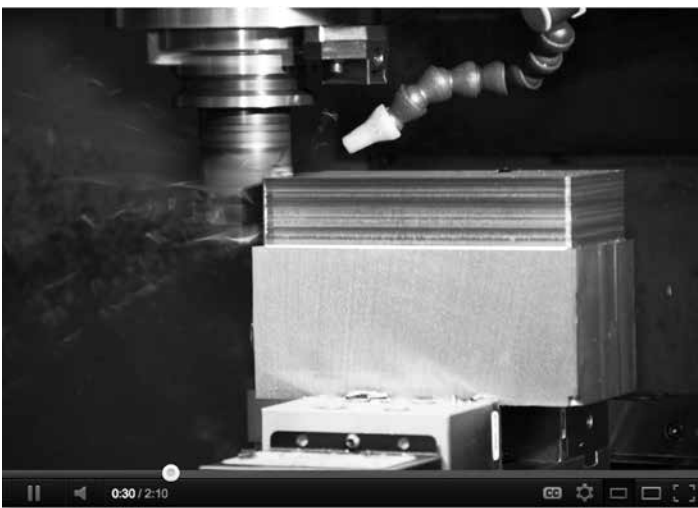

Milling on vertical machining centre



Milling on 5 axis



SinterGrip can be used with all the mechanical, mechanical-hydraulic or hydraulic clamping systems. For all the other clamping systems, please check the compatibility of these systems with grippers.

SinterGrip is proposed in the following possibilities:

ALL IN ONE

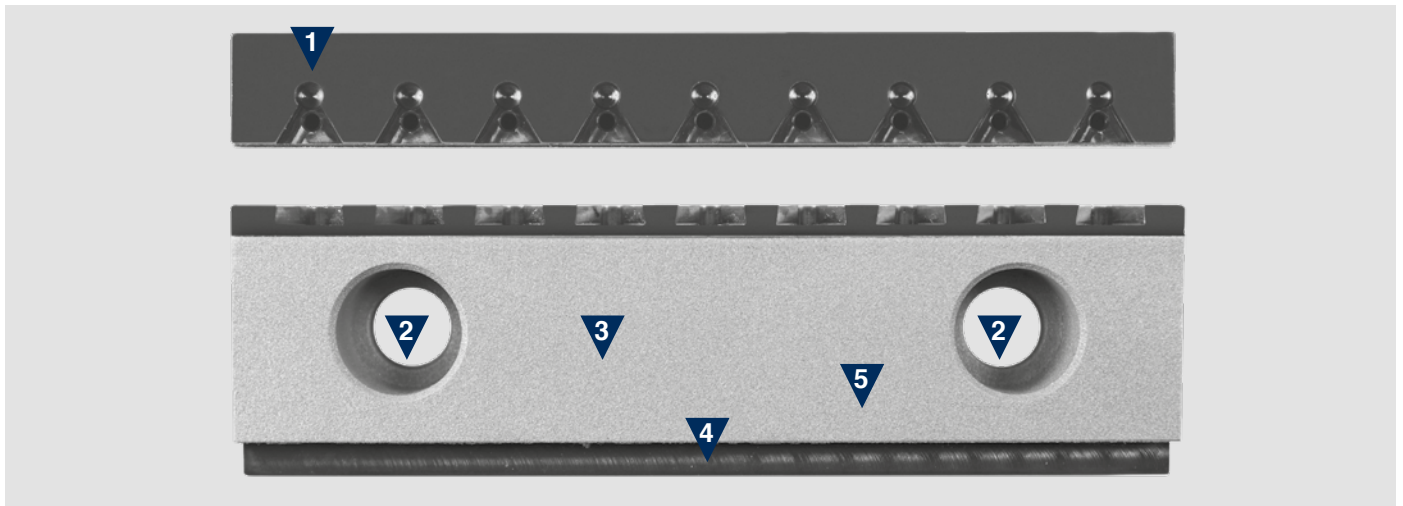

- 1 Shape of the self-centering seat of the insert with dovetail interlocking
- 2 Fixing holes to the vise
- 3 Tungsten carbide coating for better grip in the second operation
- 4 Seat for Clak system
- 5 Made of steel with tensile strength $\approx 1.080 \text{ N/mm}^2$ + nitriding



STANDARD



- 1** Shape of the self-centering seat of the insert with dovetail interlocking
- 2** Fixing holes to the vise
- 3** Seat for Clak system
- 4** Made of steel with tensile strength $\approx 1.080 \text{ N/mm}^2$ + nitriding

STARTER KIT

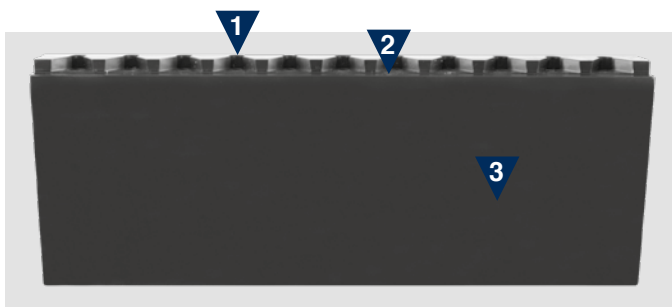

- 1** Shape of the self-centering seat of the insert with dovetail interlocking
- 2** Step 3,5x4 mm
- 3** Made of steel with tensile strength $\approx 980 \text{ N/mm}^2$ + nitriding

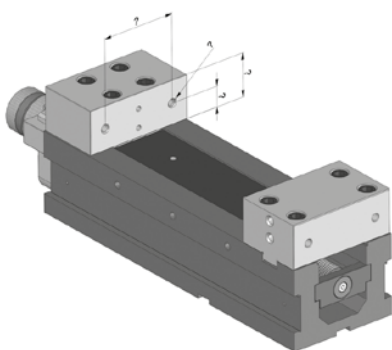

Take the necessary dimensions of your vise

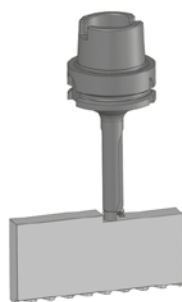

Mill the jaws to the necessary height

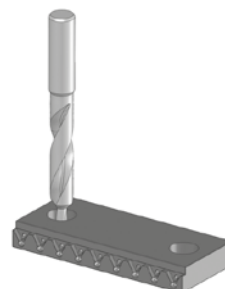

Drill the jaws at the same height of the supports of the vise

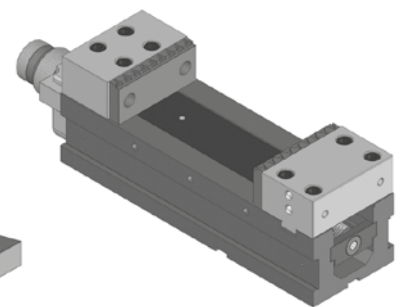

Mount the kit on your vise

ALL IN ONE



Pair of jaws with tungsten carbide coating.

The set includes one pair of jaws, 1 pair of parallels (**PP**), 1 wrench TORX T9 and one kit of 10 screws.

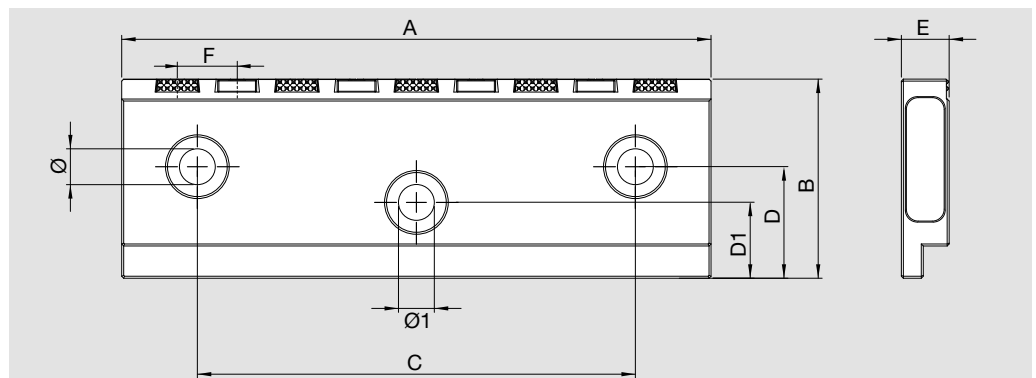

Check the dimensions of your jaws before purchasing

Model	Id. No.	A	B	C	D	D1	E	Ø	Ø1	H parallels	F	n. inserts
		mm	mm	mm	mm	mm	mm	mm	mm	mm	mm	
ALLMATIC - T-REX / TITAN	58452119	124,4	39,5	88	12,3	18	12	7	11	36,5	14	9
GRESSEL/WNT / SCHUNK / FRESMAK / VP-N	58452129	125	40	80	15	-	12	9	-	36,5	14	9
OML - VISE POWER	58452139	130	52	90	25	-	12	11	-	49	14	9
HILMA	58452149	125	45	80	14	-	12	9	-	42	14	9
OML - TC 110 mm	58452159	106	40	80	23	-	12	7	-	37	15	7
OML - TC/MC 150 mm	58452219	148	50	110	28	-	12	9	-	47	15	9
KURT 6"	58452229	152	44,1	98,4	23,6	-	18,4	13,5	-	35	15,875	9
ALLMATIC - T-REX / TITAN	58452319	160	49,8	88	12,3	20	12	7	11	47	14	11
GRESSEL/WNT / SCHUNK / FRESMAK	58452329	160	50	100	20	-	12	11	-	47	14	11
OML - VISE POWER	58452339	160	55	90	25	-	12	11	-	52	14	11
HILMA	58452349	160	54	100	17	-	12	11	-	51	14	11
OML - TC/MC 200 mm	58452419	196	70	130	49	-	18	9	-	67	15	13

Special jaws "All in one" upon request

STANDARD



Pair of jaws without tungsten carbide coating.

The set includes one pair of jaws, 1 pair of parallels (PP), 1 wrench TORX T9 and 1 kit of 10 screws.

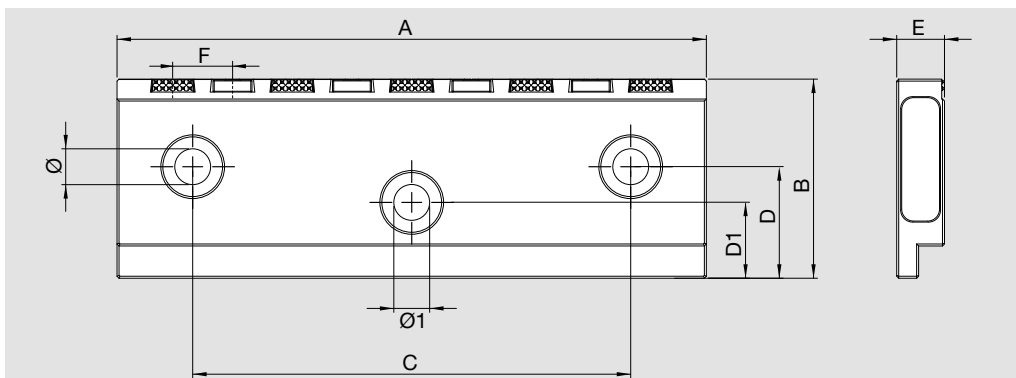

Check the dimensions of your jaws before purchasing

Model	Id. No.	A	B	C	D	D1	E	Ø	Ø1	H parallels	F	n. inserts
		mm	mm	mm	mm	mm	mm	mm	mm	mm	mm	
ALLMATIC - T-REX / TITAN	58451119	124,4	39,5	88	12,3	18	12	7	11	36,5	14	9
GRESSEL/WNT / SCHUNK / FRESMAK / VP-N	58451129	125	40	80	15	-	12	9	-	36,5	14	9
OML - VISE POWER	58451139	130	52	90	25	-	12	11	-	49	14	9
HILMA	58451149	125	45	80	14	-	12	9	-	42	14	9
OML - TC 110 mm	58451159	106	40	80	23	-	12	7	-	37	15	7
OML - TC/MC 150 mm	58451219	148	50	110	28	-	12	9	-	47	15	9
KURT 6"	58451229	152	44,1	98,4	23,6	-	18,4	13,5	-	35	15,875	9
ALLMATIC - T-REX / TITAN	58451319	160	49,8	88	12,3	20	12	7	11	47	14	11
GRESSEL/WNT / SCHUNK / FRESMAK	58451329	160	50	100	20	-	12	11	-	47	14	11
OML - VISE POWER	58451339	160	55	90	25	-	12	11	-	52	14	11
HILMA	58451349	160	54	100	17	-	12	11	-	51	14	11
OML - TC/MC 200 mm	58451419	196	70	130	49	-	18	9	-	67	15	13

Special jaws "All in one" upon request

STANDARD



Model	Id. No.
OML - GENIUS	58451519

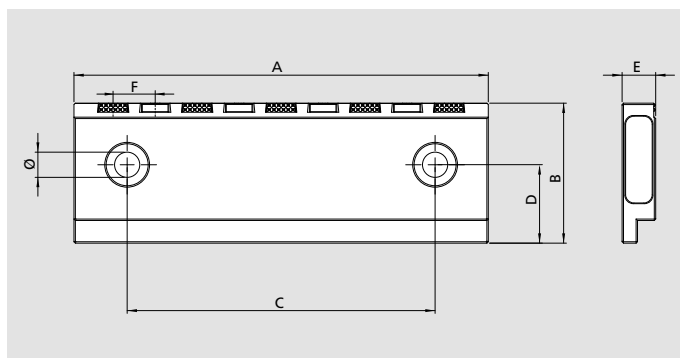
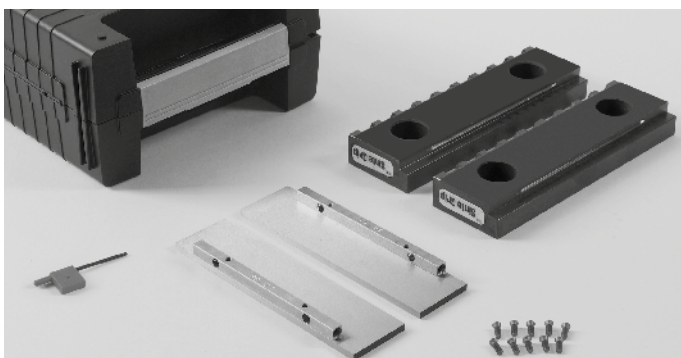

Pair of jaws without tungsten carbide coating.

The set includes one pair of jaws, 1 pair of parallels (H35 thickness 6 mm), 1 wrench TORX T9 and 1 kit of 10 screws.

Type	Id. No.	A	B	C	D	E	Ø	H parallels	F	n. inserts
		mm	mm	mm	mm	mm	mm	mm	mm	
Kit 1 Op Sint. 150 XL	50240520	148	50	110	28	12	9	35	15	9

STARTER KIT

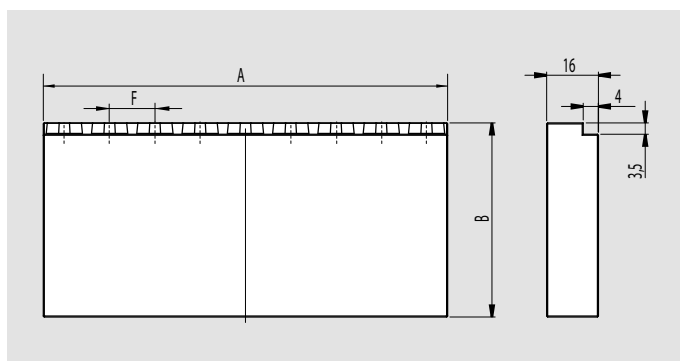
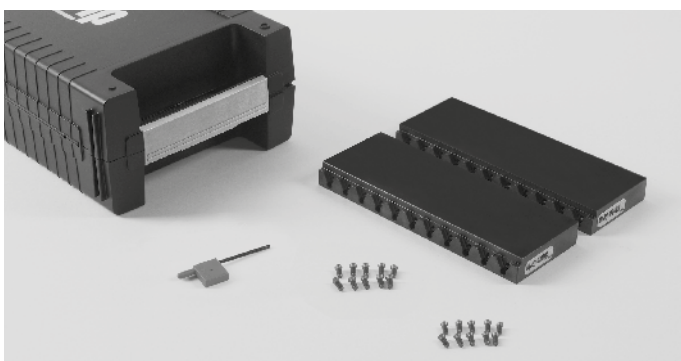

Pair of jaws.

The set includes one pair of jaws, 1 wrench TORX T9 and 1 kit of 10 screws

Id. No.	A	B	F	n. inserts
	mm	mm	mm	
58453119	125	59	14	9
58453319	160	59	14	11
58453419	200	70	15	13

SINTERGRIP



SinterGrip inserts. The set includes n. 10 inserts

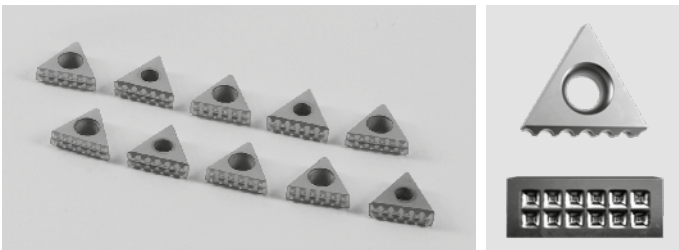

Id. No.	Description
58450119	Set of 10 SinterGrip inserts STD for steel

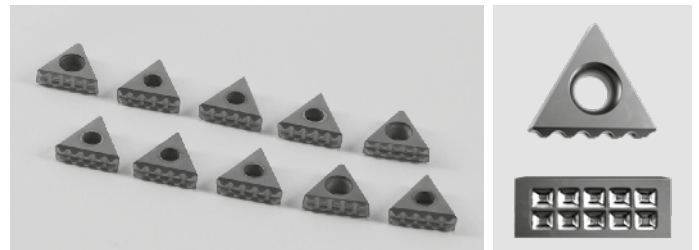

Id. No.	Description
58450129	Set of 10 SinterGrip inserts HRC for hardened steel / titanium until 50-54 HRC

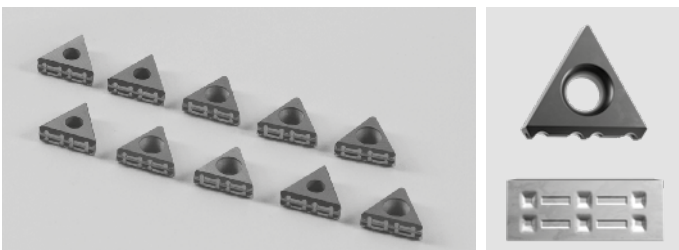

Id. No.	Description
58450139	Set of 10 SinterGrip inserts ALU for aluminium



Id. No.	Description
58450149	Set of 10 SinterGrip inserts PLM for polymeric materials

ACCESSORI

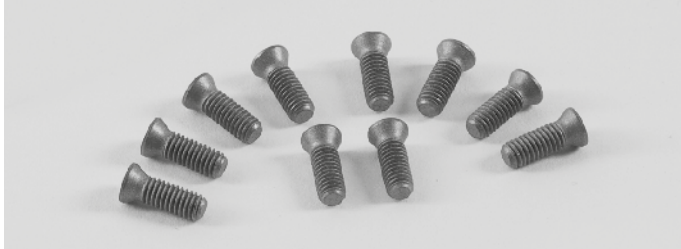

Id. No.	Description
58450219	Set 10VTX30 for inserts SINTERGRIP

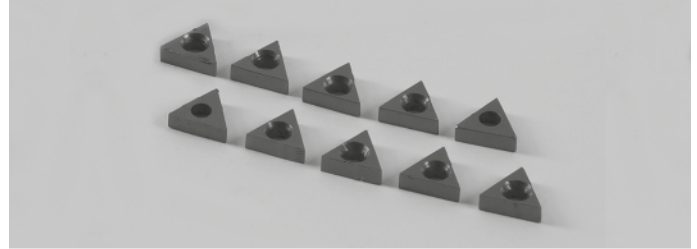

Id. No.	Description
58450519	Set 10 protection inserts in aluminum

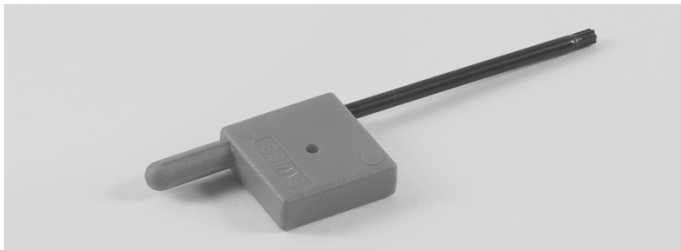

Id. No.	Description
58450320	Wrench TORX T9

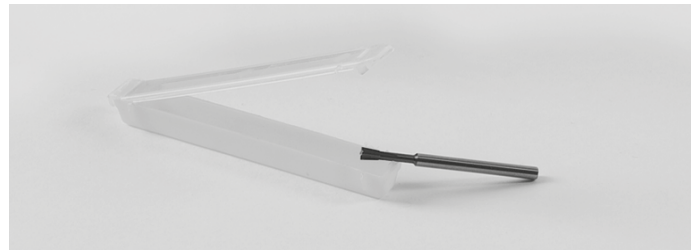

Id. No.	Description
58450410	Special cutting tool D3

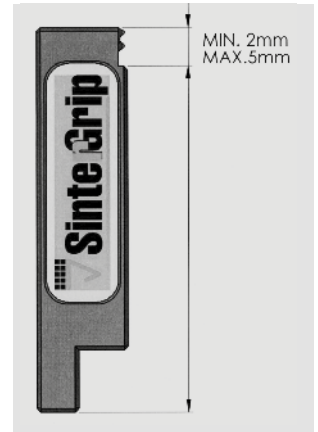

Quick change modular parallels for OML vises TC/MC
The set includes n. 6 pairs of parallels

2nd Op. No need to disassemble the inserts

Id. No.	Model	A	B	C
		mm	mm	mm
58459216	OML TC/MC 150 mm	146	20/25/30/35/45* / 48**	3
58459416	OML TC/MC 200 mm	195	25/35/45/55/65* /68**	3

* SinterGrip clamping surface 5 mm
** SinterGrip clamping surface 2 mm

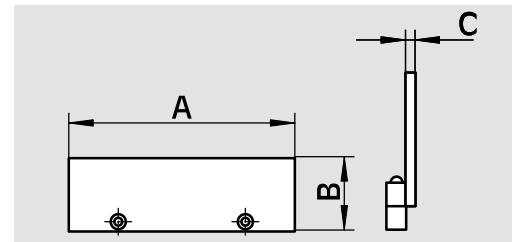

UNIVERSAL quick change modular parallels
The set includes n. 6 pairs of parallels

Id. No.	Model	A	B	C
		mm	mm	mm
58459116	ALLMATIC GRESSEL/WNT/SCHUNK/FRESMAK	124	15/20/25/30/35* /37,5**	4
58459136	WISE POWER	124	15/20/25/30/37,5* /50**	4
58459146	HILMA	124	15/20/25/30/40* /43**	4
58459226	KURT 6"	149	15/20/25/30/39* /42**	4
58459236	OML - LC / GERARDI 150 mm	149	15/20/25/30/58* /61**	4

58459316	ALLMATIC GRESSEL/WNT/SCHUNK/FRESMAK	159	15/25/35/40/45* /48**	4
58459336	WISE POWER	159	15/25/35/40/50* /53**	4
58459346	HILMA	159	15/25/35/40/49* /52**	4

* SinterGrip clamping surface 5 mm
** SinterGrip clamping surface 2 mm

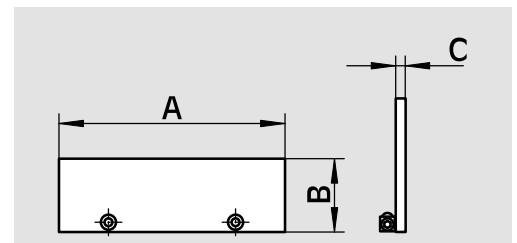

Order example for special executions

- 58450410 - cutting tool D3
- 58450119 - set 10 inserts STD
- 58450219 - set 10 screws VTX30



Order example for jaws

- 58452219 - pair of jaws All in One
- 58450119 - set 10 inserts STD
- 58450519 - kit 10 protection inserts



APS

Zero Point Clamping System

