

# The advantages of modularity

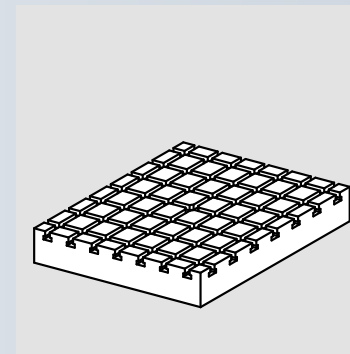
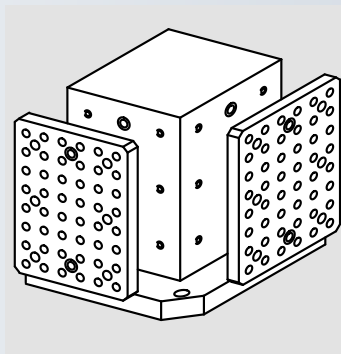
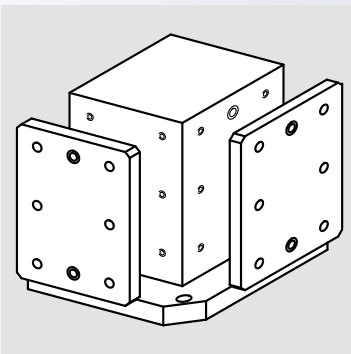
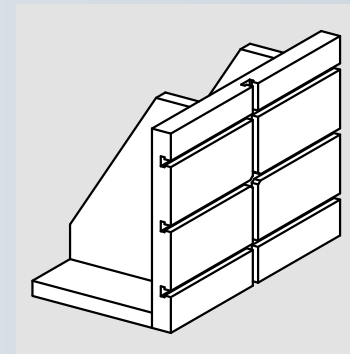
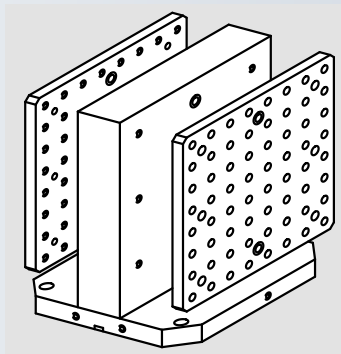
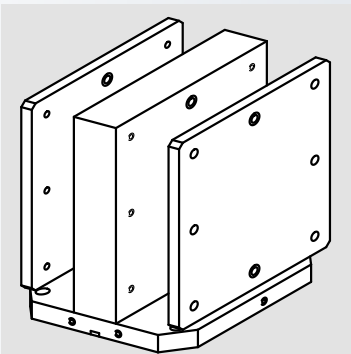
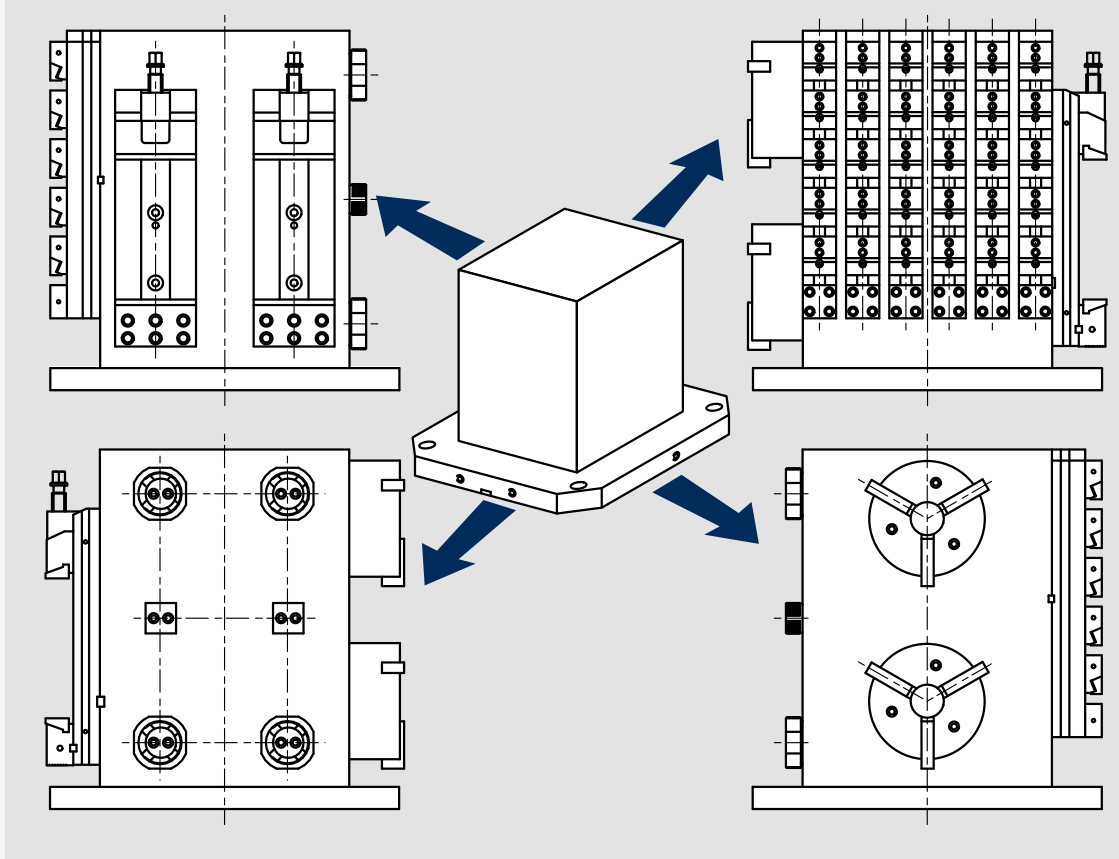

# Modular Tombstone

## Tombstones

■ Standard adaptation for machine tools pallet

Our products (tombstones, crankwebs) are supplied standard with the base machined to the table of the machine tool as follows.

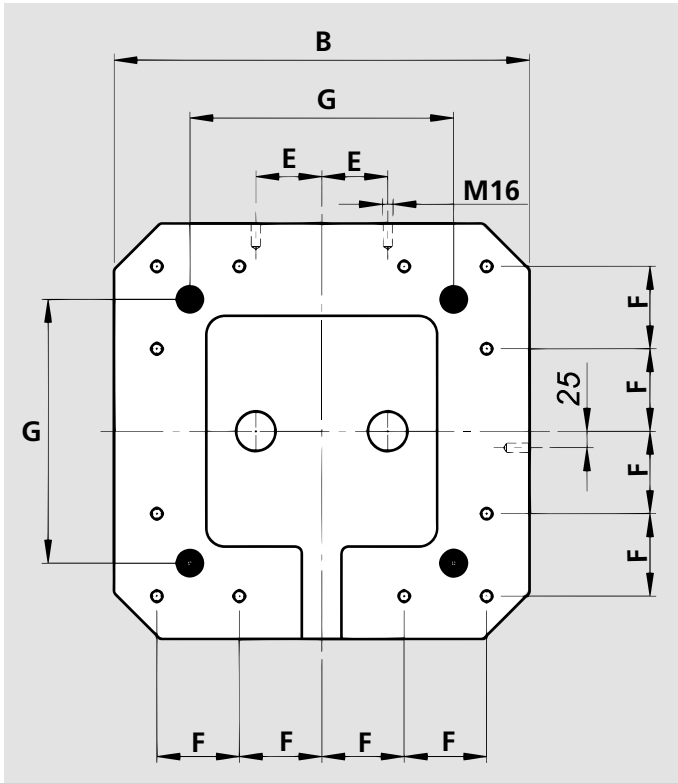

B mm	E mm	F mm	G mm
300	on request	on request	on request
400	55	80	250
500	75	100	250
630	100	125	420
800	135	160	420

## Manufacturing tolerances

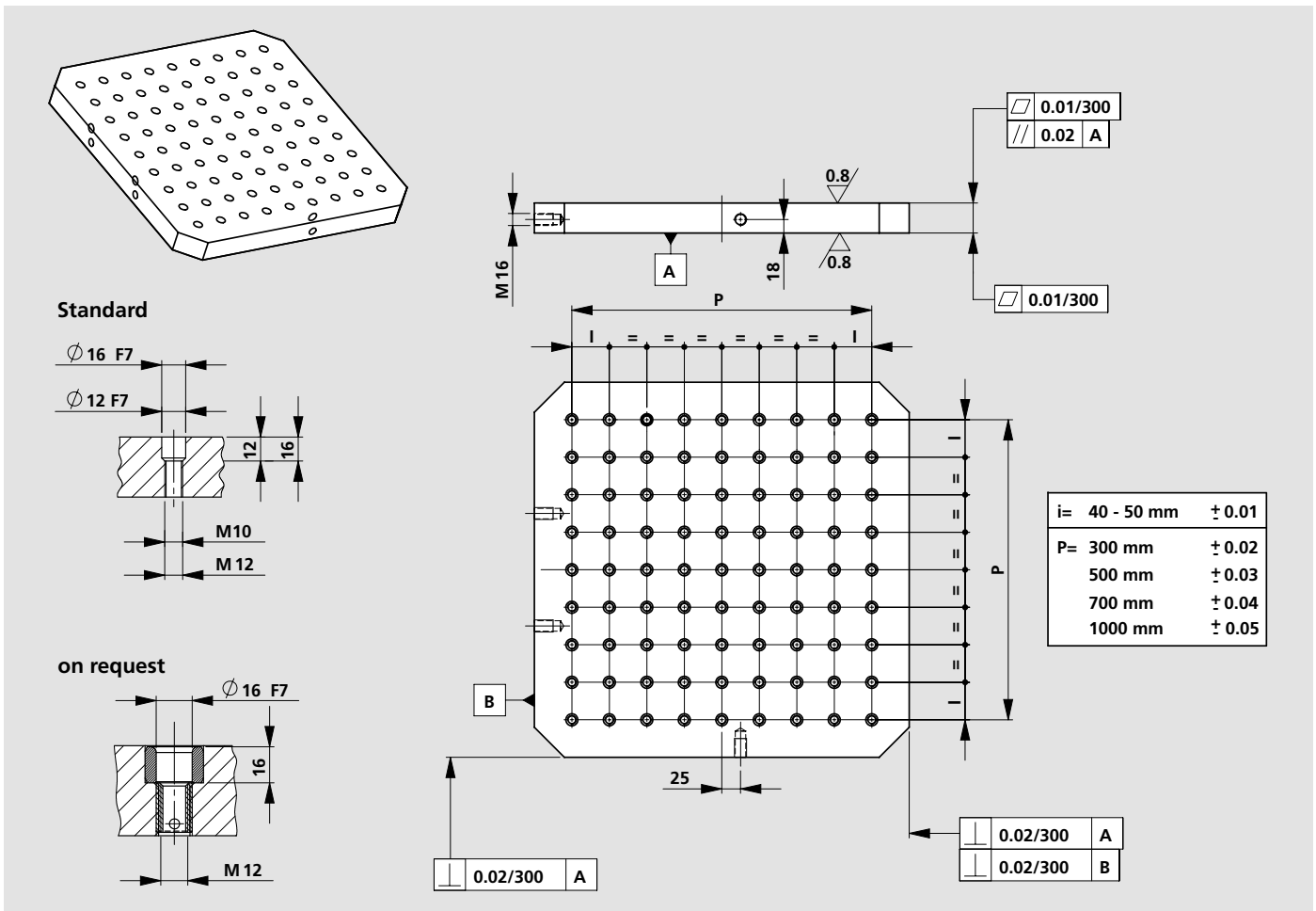

Tombstones only milled finished

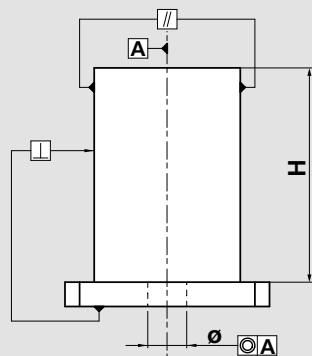

H	⊥	//	⊙
500 mm	0.020	0.020	0.020
1000 mm	0.035	0.035	0.035

Tombstones for plates

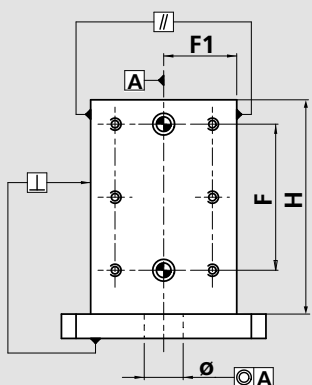

H	⊥	//	⊙
500 mm	0.020	0.020	0.020
1000 mm	0.035	0.035	0.035

F=	300 mm	± 0.02
	500 mm	± 0.03
	700 mm	± 0.04
F1=	500 mm	± 0.015
	1000 mm	± 0.025

Tombstones with grid

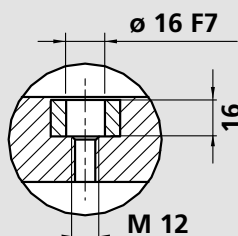
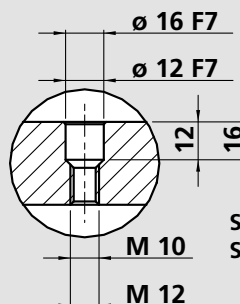
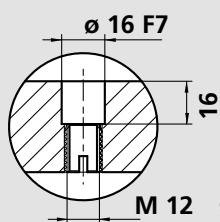

H	⊥	//	⊙
500 mm	0.020	0.020	0.020
1000 mm	0.035	0.035	0.035

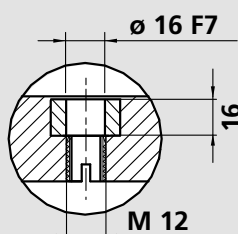
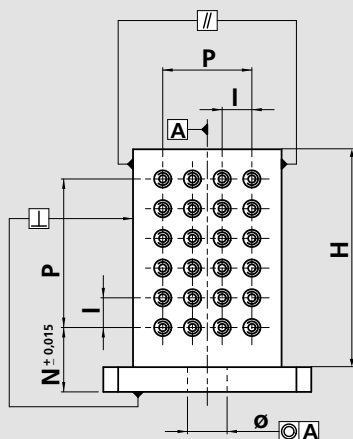

i=	40 - 50 mm	± 0.01
P=	300 mm	± 0.02
	500 mm	± 0.03
	700 mm	± 0.04
	1000 mm	± 0.05